

Rev.No.	Ch.Let	Alterations	Date	Sign.	Appd.

All Dimensions are in MM

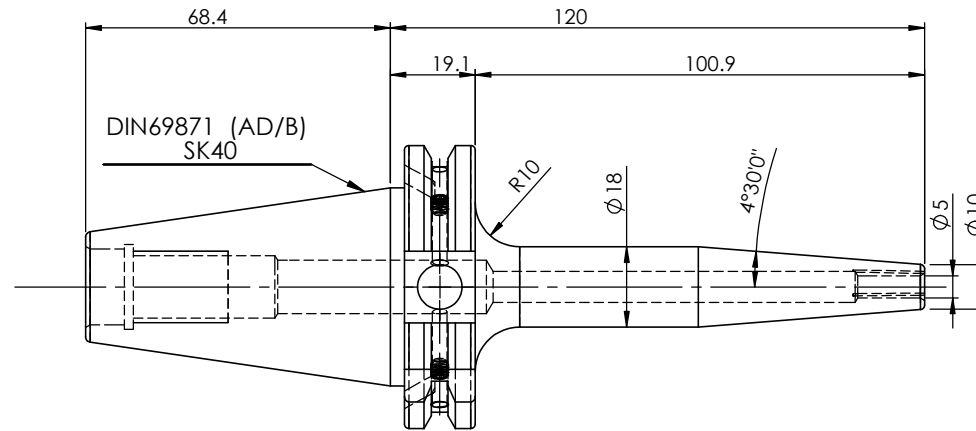
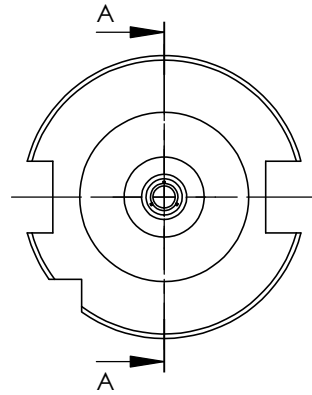
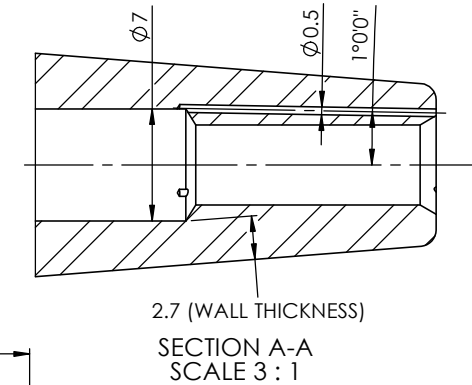
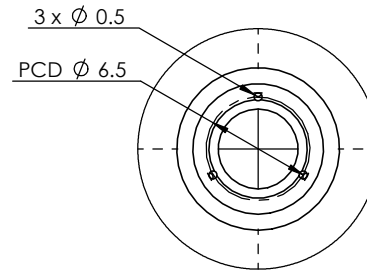
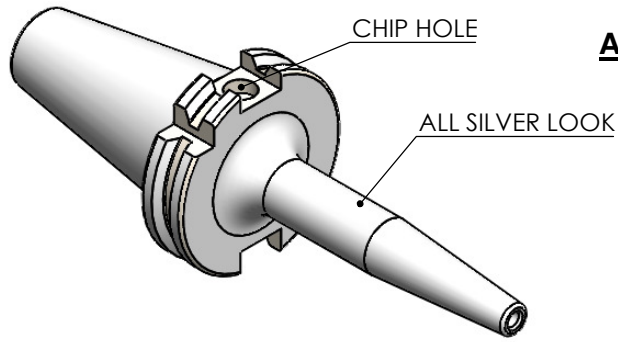

LABEL :

2002266.0501
SCHRUMPFUTTER MIT KK
SHRINK FIT HOLDER COOLANT CHANNEL
ISO 7388-1 (DIN69871) SK40 AD/AF (AD+B)
SR4 05mm X 120mm
G2,5/25000 U/MIN

MARKING : ISO 7388-1 (DIN69871) SK40 AD/AF (AD+B) SFHC05H120
G2,5/25000 U/MIN

NOTE: WITHOUT BALANCING SCREW HOLES

ITEM NO.	PART NUMBER	DESCRIPTION	QTY.
1	F1S409H-SFK05120	SK40SFK05120FWW	1
2	GS-M4X4	GRUB SCREW	2

NOTE :

BALANCING 2.5G@ 25000 RPM

Weight : 0.9 Kg

μ m	0.012	0.025	0.05	0.1	0.2	0.4	0.8	1.6	3.2	6.3	12.5	25	50
GRADES	N1	N2	N3	N4	N5	N6	N7	N8	N9	N10	N11	N12	
SYMBOLS	▽▽▽			▽▽▽			▽▽			▽			~
TOLERANCE FREE DIMENSIONS TOLERANCE	2022		NAME		DATE		WEMAG 2002266.0501						
HDS	DRAWN		SVR		29/01								
Dimns. Dia Length	CHECKED		RVL		29/01								
0.5 to 3 ± 0.05 ± 0.10	APPROVED												
3 to 6 ± 0.10 ± 0.15	SCALE : NTS		QTY. :		PART NAME:						DRAWING No.	REV.	
6 to 30 ± 0.15 ± 0.20					SK40SFK05120FWW						F1S409H-SFK05120	00	
30 to 120 ± 0.20 ± 0.25													
120 to 500 ± 0.30 ± 0.50													