

Rev.No.	Ch.Let	Alterations	Date	Sign.	Appd.

**All Dimensions are in MM**

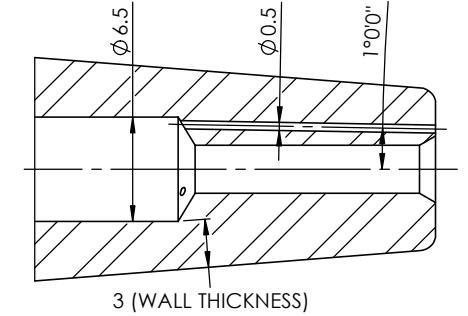

SECTION A-A  
SCALE 3 : 1

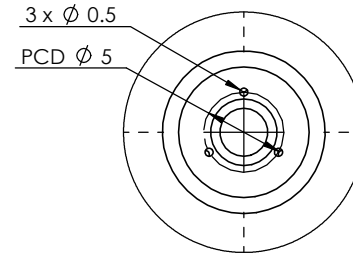
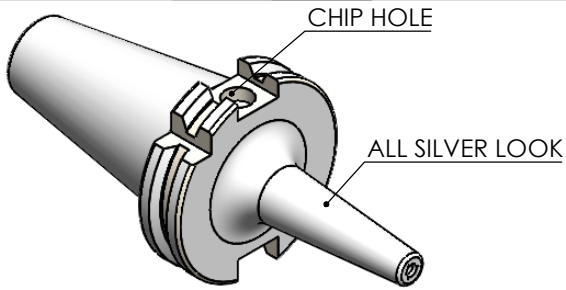
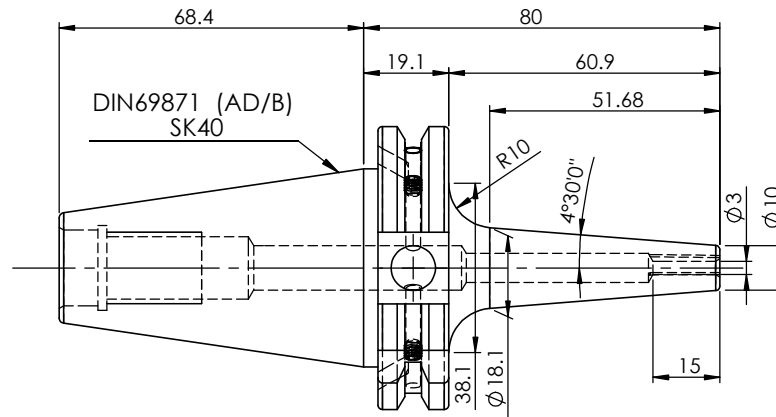
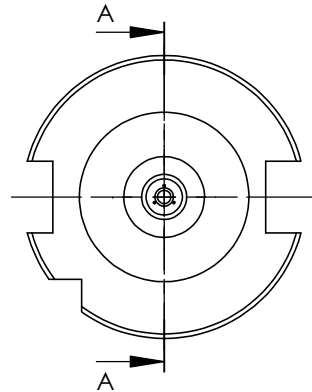

**LABEL :**

**2002266.0300**  
**SCHRUMPFUTTER MIT KK**  
**SHRINK FIT HOLDER COOLANT CHANNEL**  
**ISO 7388-1 (DIN69871) SK40 AD/AF (AD+B)**  
**SR4 03mm X 080mm**  
**G2,5/25000 U/MIN**

**MARKING : ISO 7388-1 (DIN69871) SK40 AD/AF (AD+B) SFHC03H080**  
**G2,5/25000 U/MIN**

**NOTE: WITHOUT BALANCING SCREW HOLES**

ITEM NO.	PART NUMBER	DESCRIPTION	QTY.
1	FWS409H-SFK03080	SK40SFK03080FWW	1
2	GS-M4X4	GRUB SCREW	2

**NOTE :**

**BALANCING 2.5G@ 25000 RPM**

**Weight : 0.9 Kg**

μ m	0.012	0.025	0.05	0.1	0.2	0.4	0.8	1.6	3.2	6.3	12.5	25	50
GRADES	N1	N2	N3	N4	N5	N6	N7	N8	N9	N10	N11	N12	
SYMBOLS	▽▽▽			▽▽▽			▽▽			▽			~
TOLERANCE	MATERIALS:			2022	NAME	DATE							
FREE DIMENSIONS	HDS			DRAWN	SVR	29/01							
TOLERANCE	CHECKED			RVL		29/01							
Dimns.	Dia	Length	APPROVED										
0.5 to 3	± 0.05	± 0.10	SCALE : NTS			QTY. :							
3 to 6	± 0.10	± 0.15	PART NAME:			DRAWING No.							
6 to 30	± 0.15	± 0.20	SK40SFK03080FWW			FWS409H-SFK03080							
30 to 120	± 0.20	± 0.25	REV.			00							
120 to 500	± 0.30	± 0.50											