

Rev.No.	Ch.Let	Alterations	Date	Sign.	Appd.

All Dimensions are in MM

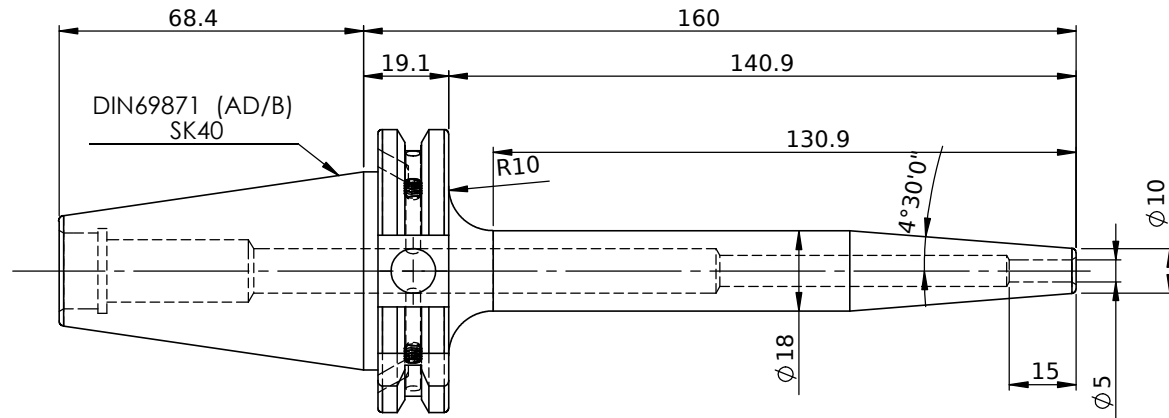
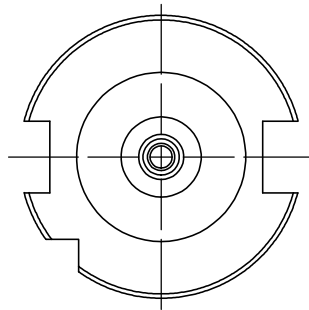
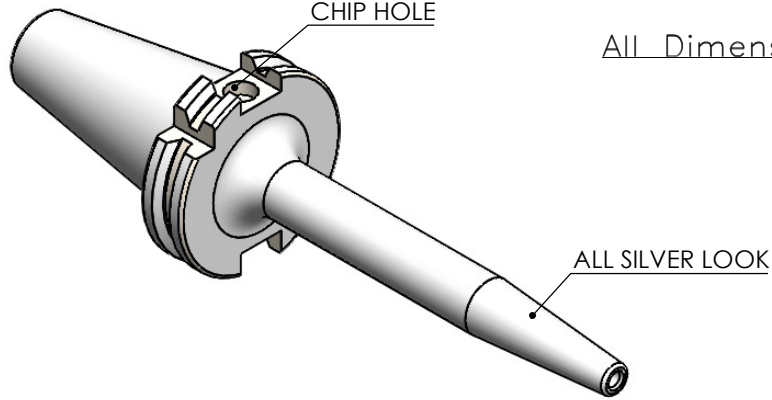

LABEL :

2002265.0502
SCHRUMPFUTTER
SHRINK FIT HOLDER
ISO 7388-1 (DIN69871) SK40 AD/AF (AD+B)
SR2 05mm X 160mm
G2,5/25000 U/MIN

MARKING : ISO 7388-1 (DIN69871) SK40 AD/AF (AD+B) SR05H160
G2,5/25000 U/MIN

NOTE: WITHOUT BALANCING SCREW HOLES

ITEM NO.	PART NUMBER	DESCRIPTION	QTY.
1	F1S409H-SFC05160	SK40SFC05160FWW	1
2	GS-M4X4	GRUB SCREW	2

NOTE :

BALANCING 2.5G@ 25000 RPM

Weight : 0.98 Kg

	µm	0.012	0.025	0.05	0.1	0.2	0.4	0.8	1.6	3.2	6.3	12.5	25	50			
GRADES		N1	N2	N3	N4	N5	N6	N7	N8	N9	N10	N11	N12				
SYMBOLS		▽▽▽	▽▽	▽	▽	▽	▽	▽	▽	▽	▽	▽	▽	~			
TOLERANCE	MATERIALS:	2023	NAME	DATE	WEMAG 2002265.0502												
FREE DIMENSIONS	HDS	DRAWN	25/03														
TOLERANCE		CHECKED	25/03														
		APPROVED															
Dimns.	Dia	Length	SCALE : NTS		QTY. :		PART NAME:								DRAWING No.		REV.
0.5 to 3	±0.05	±0.10					SK40SFC05160FWW								F1S409H-SFC05160		00
3 to 6	±0.10	±0.15															
6 to 30	±0.15	±0.20															
30 to 120	±0.20	±0.25															
120 to 500	±0.30	±0.50															