

Rev.No.	Ch.Let	Alterations	Date	Sign.	Appd.

All Dimensions are in MM

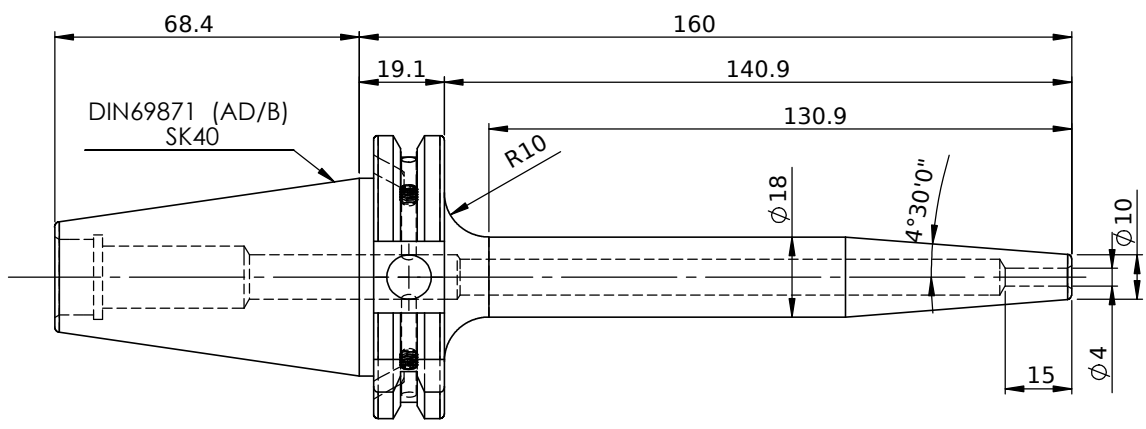
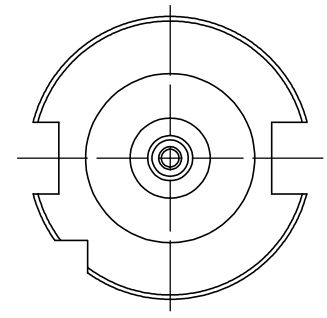
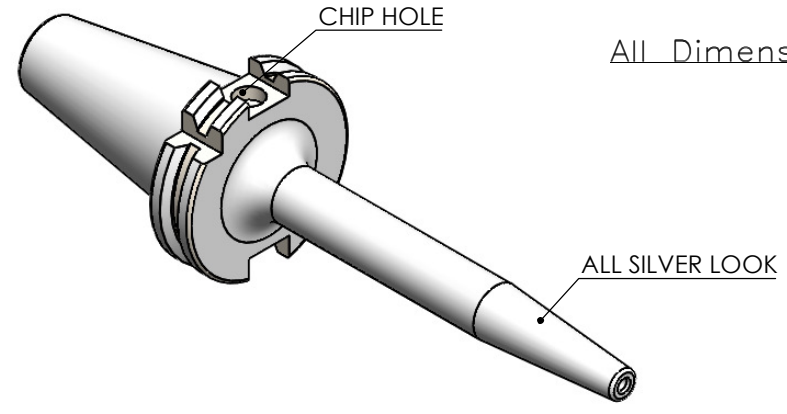

**LABEL :**

**2002265.0402**  
**SCHRUMPFUTTER**  
**SHRINK FIT HOLDER**  
**ISO 7388-1 (DIN69871) SK40 AD/AF (AD+B)**  
**SR2 04mm X 160mm**  
**G2,5/25000 U/MIN**

**MARKING : ISO 7388-1 (DIN69871) SK40 AD/AF (AD+B) SR04H160**  
**G2,5/25000 U/MIN**

**NOTE: WITHOUT BALANCING SCREW HOLES**

ITEM NO.	PART NUMBER	DESCRIPTION	QTY.
1	F1S409H-SFC04160	SK40SFK04160FWW	1
2	GS-M4X4	GRUB SCREW	2

**NOTE :**

**BALANCING 2.5G@ 25000 RPM**

**Weight : 1.0 Kg**

	µm	0.012	0.025	0.05	0.1	0.2	0.4	0.8	1.6	3.2	6.3	12.5	25	50
	GRADES	N1	N2	N3	N4	N5	N6	N7	N8	N9	N10	N11	N12	
	SYMBOLS	▽▽▽	▽▽	▽	▽	▽	▽	▽	▽	▽	▽	▽	▽	~
TOLERANCE		MATERIALS:		2023		NAME		DATE		<b>WEMAG</b> <b>2002265.0402</b>				
FREE DIMENSIONS		HDS		DRAWN		EJK		25/03						
TOLERANCE				CHECKED		RUL		25/03						
				APPROVED										
Dimns.	Dia	Length			SCALE : NTS		QTY. :		PART NAME:					
0.5 to 3	±0.05	±0.10							SK40SFC04160FWW					
3 to 6	±0.10	±0.15							DRAWING No.					
6 to 30	±0.15	±0.20							F1S409H-SFC04160					
30 to 120	±0.20	±0.25							REV.					
120 to 500	±0.30	±0.50							00					