

All Dimensions are in MM

Rev.No	Ch.Let	Alterations	Date	Sign.	Appd.

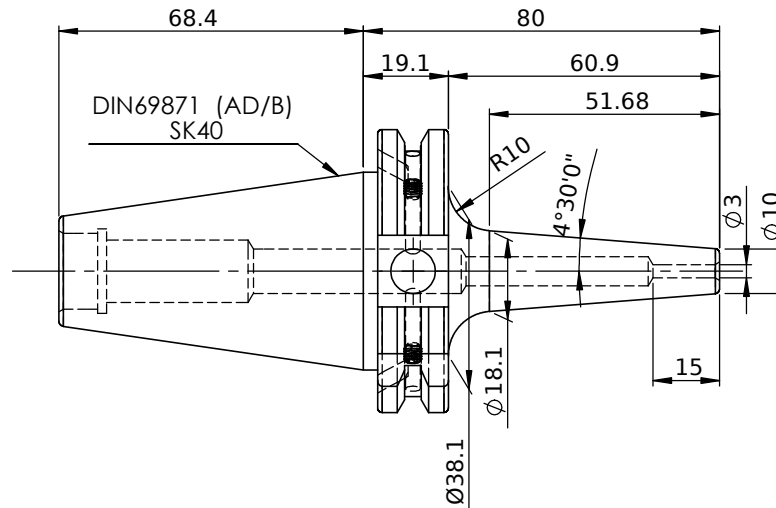
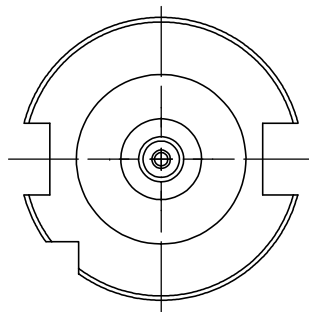

LABEL :

2002265.0300
SCHRUMPFUTTER
SHRINK FIT HOLDER
ISO 7388-1 (DIN69871) SK40 AD/AF (AD+B)
SR2 03mm X 080mm
G2,5/25000 U/MIN

MARKING : ISO 7388-1 (DIN69871) SK40 AD/AF (AD+B) SR03H080
G2,5/25000 U/MIN

NOTE: WITHOUT BALANCING SCREW HOLES

ITEM NO.	PART NUMBER	DESCRIPTION	QTY.
1	F1S409H-SFC03080	SK40SFC03080FWW	1
2	GS-M4X4	GRUB SCREW	2

NOTE :

BALANCING 2.5G@ 25000 RPM

Weight : 0.9 Kg

µm	0.012	0.025	0.05	0.1	0.2	0.4	0.8	1.6	3.2	6.3	12.5	25	50		
GRADES	N1	N2	N3	N4	N5	N6	N7	N8	N9	N10	N11	N12			
SYMBOLS	▽▽▽			▽▽▽			▽▽			▽		~			
TOLERANCE	MATERIALS:			2023		NAME		DATE							
FREE DIMENSIONS	HDS			DRAWN		EJK		25/03							
TOLERANCE	Dimns.			Dia		Length		CHECKED		RVL				25/03	
0.5 to 3	±0.05		±0.10		±0.10		APPROVED								
3 to 6	±0.10		±0.15		±0.15		SCALE : NTS		QTY. :						
6 to 30	±0.15		±0.20		±0.20		PART NAME:		SK40SFC03080FWW				DRAWING No.		
30 to 120	±0.20		±0.25		±0.25		DRAWING No.		F1S409H-SFC03080				REV.		
120 to 500	±0.30		±0.50		±0.50		SCALE : NTS		QTY. :				00		

WEMAG
2002265.0300