

Rev.No.	Ch.Let	Alterations	Date	Sign.	Appd.

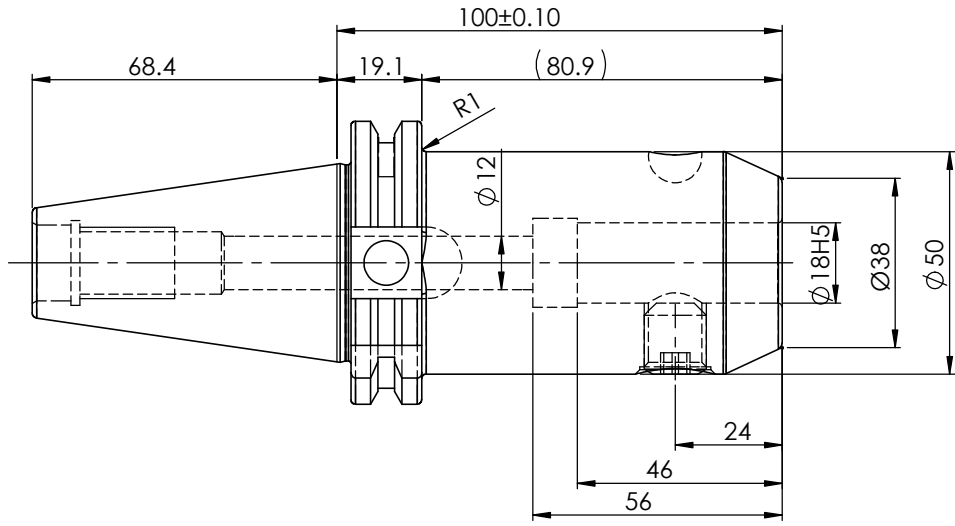
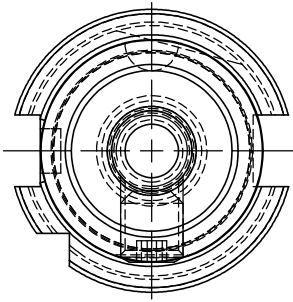
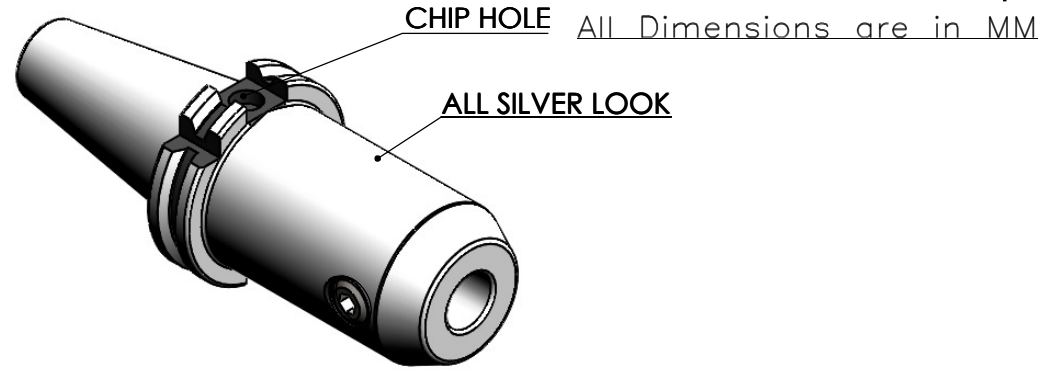

**LABEL :**

**2002263.1801  
WELDON-AUFNAHME  
WELDON HOLDER  
DIN69871 SK40 AD  
WE 18 mm x 100 mm  
G6.3 / 15000 U/MIN**

**MARKING : DIN 69871 AD SK40 WE18H100  
G6.3 15000 U/MIN**

**NOTE :**

**BALANCING 6.3G @ 15000 RPM**

**WEIGHT : 1.8 kg**

ITEM NO.	PART NUMBER	DESCRIPTION	QTY.
1	GS-M14X16-DIN1835-B	GRUB SCREW	1
2	SK40EM18100WW	END MILL HOLDER	1

µm	0.012	0.025	0.05	0.1	0.2	0.4	0.8	1.6	3.2	6.3	12.5	25	50
GRADES	N1	N2	N3	N4	N5	N6	N7	N8	N9	N10	N11	N12	
SYMBOLS	▽▽▽			▽▽▽			▽▽			▽			~
TOLERANCE	MATERIALS:			2019	NAME	DATE	<b>WEMAG</b> <b>2002263.1801</b>						
FREE DIMENSIONS	16MnCr5			DRAWN	PK	09/10							
TOLERANCE				CHECKED	RVL	09/10							
Dimns.	Dia	Length		APPROVED									
0.5 to 3	±0.05	±0.10		SCALE : NTS	QTY. :								
3 to 6	±0.10	±0.15		PART NAME:		DRAWING No.							
6 to 30	±0.15	±0.20		<b>SK40EM18100WW</b>		<b>FWS401A-EMH18100</b>							
30 to 120	±0.20	±0.25				REV.							
120 to 500	±0.30	±0.50				00							