

All Dimensions are in MM

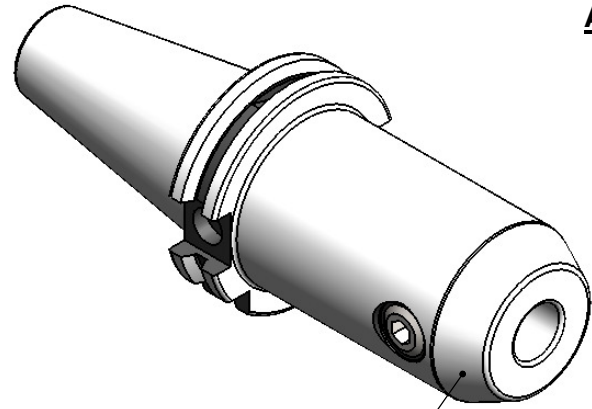

ALL SILVER LOOK

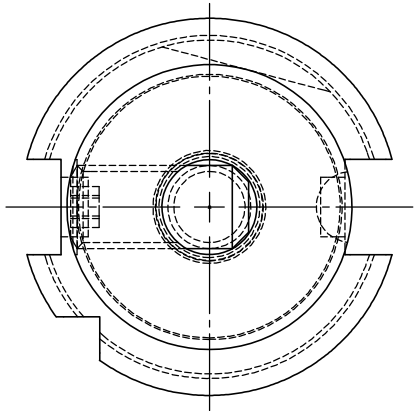

Label :

2002263.1601
WELDON-AUFNAHME
WELDON HOLDER
DIN69871 SK40 AD
 WE 16 mm x 100 mm
 G6.3 / 15000

NOTE :

BALANCING G6.3 AT 15000 RPM

WEIGHT : 1.7 kg

MARKING : DIN 69871 AD SK40
 WE16H100

G6.3 15000 U/MIN

ITEM NO.	PART NUMBER	DESCRIPTION	QTY.
1	FWS401A-EMH16100	SK40 EM16 100 WW	1
2	GS-M14X16-DIN1835-B	GRUB SCREW-(B.O)	1

Rev.No.	Ch.Let	Alterations	Date	Sign.	Appd.

CUSTOMER APPROVAL REQUIRED

APPROVED BY

DATE

FOR QUOTATION PURPOSE ONLY

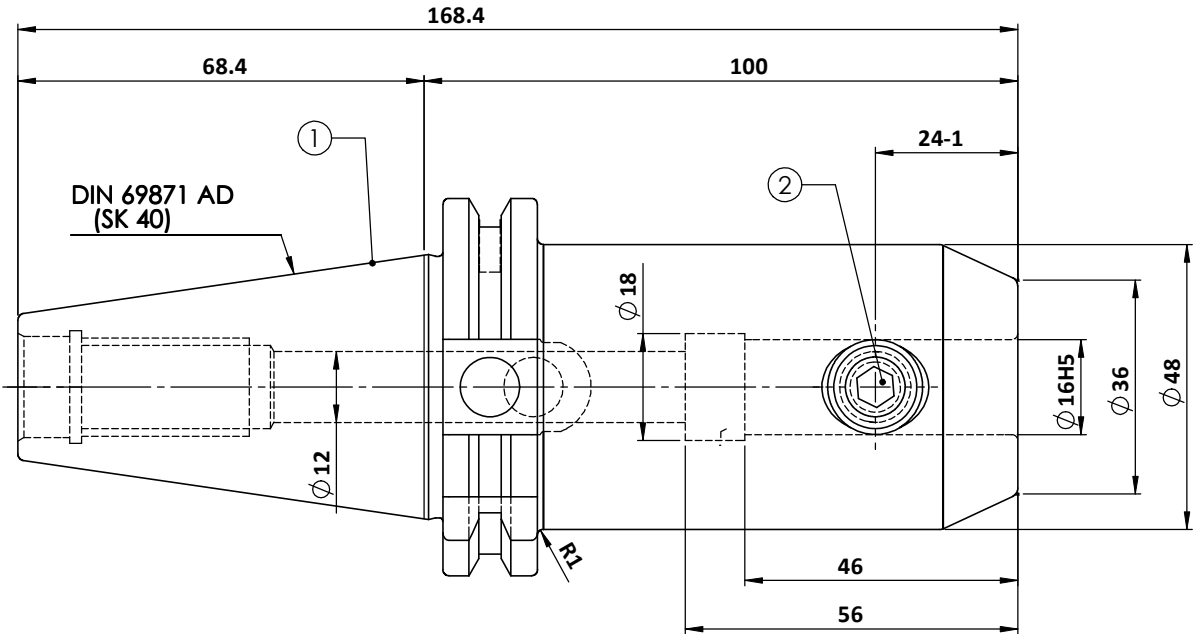

	μ	m	0.012	0.025	0.05	0.1	0.2	0.4	0.8	1.6	3.2	6.3	12.5	25	50
GRADES			N1	N2	N3	N4	N5	N6	N7	N8	N9	N10	N11	N12	
SYMBOLS			▽	▽	▽	▽	▽	▽	▽	▽	▽	▽	▽	▽	~
TOLERANCE FREE DIMENSIONS TOLERANCE	MATERIALS:		2016	NAME		DATE		<p style="text-align: center;">WEMAG 2002263.1601</p>							
0.5 to 3	± 0.05	± 0.10	16MnCr5	DRAWN	SVK	26/11									
3 to 6	± 0.10	± 0.15	CHECKED	RVL	26/11										
6 to 30	± 0.15	± 0.20	APPROVED	SCALE : NTS QTY. :											
30 to 120	± 0.20	± 0.25	PART NAME:			DRAWING No.		<p style="text-align: center;">FWS401A-EMH16100</p>							
120 to 500	± 0.30	± 0.50	END MILL HOLDER			REV.									