

**All Dimensions are in MM**

Rev.No.	Ch.Let	Alterations	Date	Sign.	Appd.

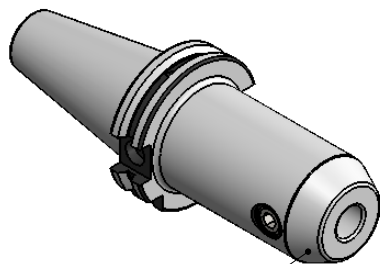

ALL SILVER LOOK

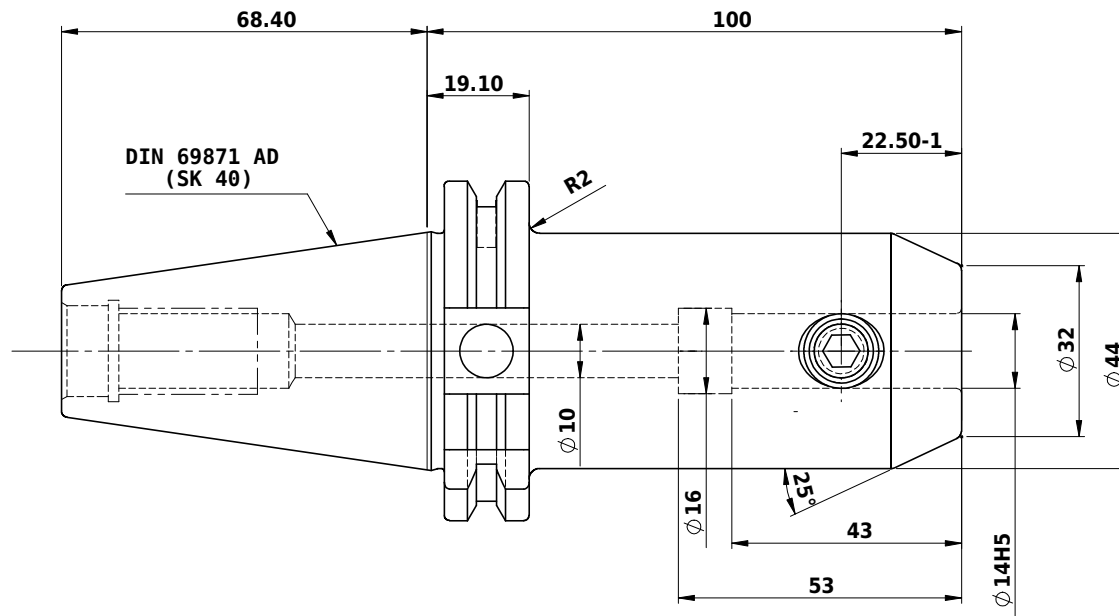
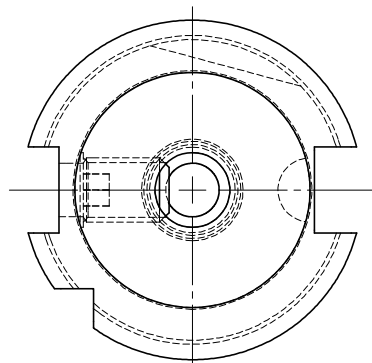

Label :  
 2002263.1401  
 WELDON-AUFNAHME  
 WELDON HOLDER  
 DIN69871 SK40 AD  
 WE 14 mm x 100 mm  
 G6.3 / 15000 U/MIN

NOTE :  
 BALANCING G6.3 AT 15000 RPM  
 WEIGHT : 1.60 kg

MARKING : DIN 69871 AD SK40 WE14H100  
 G6.3 15000 U/MIN

ITEM NO.	PART NUMBER	DESCRIPTION	QTY.
1	FWS401A-EMH14100	END MILL HOLDER	1
2	GS-M12X16-DIN1835-B	GRUB SCREW (B.O.)	1

μ m	0.012	0.025	0.05	0.1	0.2	0.4	0.8	1.6	3.2	6.3	12.5	25	50	
GRADES	N1	N2	N3	N4	N5	N6	N7	N8	N9	N10	N11	N12		
SYMBOLS	▽▽▽▽▽▽▽▽▽▽▽▽													
TOLERANCE	MATERIALS: 16MnCr5													
FREE DIMENSIONS	2018		NAME		DATE		<b>WEMAG</b> <b>2002263.1401</b>							
TOLERANCE	DRAWN		AMK		28/06									
	CHECKED		RVL		28/06									
	APPROVED													
Dimns.	Dia	Length	SCALE : NTS		QTY. :		PART NAME: SK40EM14100WW						DRAWING No. FWS401A-EMH14100	REV. 00