

All Dimensions are in MM

Rev.No.	Ch.Let	Alterations	Date	Sign.	Appd.

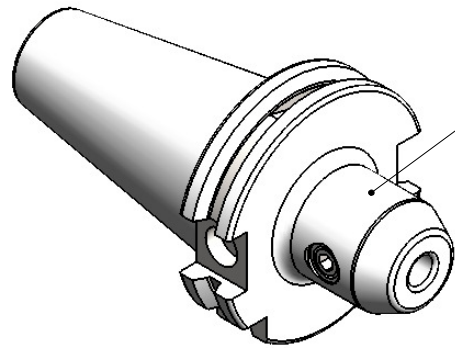

ALL SILVER LOOK

CUSTOMER APPROVAL REQUIRED

APPROVED BY

DATE

FOR QUOTATION PURPOSE ONLY

Label :
2002263.0800
WELDON-AUFNAHME
WELDON HOLDER
DIN69871 SK40 AD
WE Ø8 mm x Ø50 mm
G6.3 / 15000

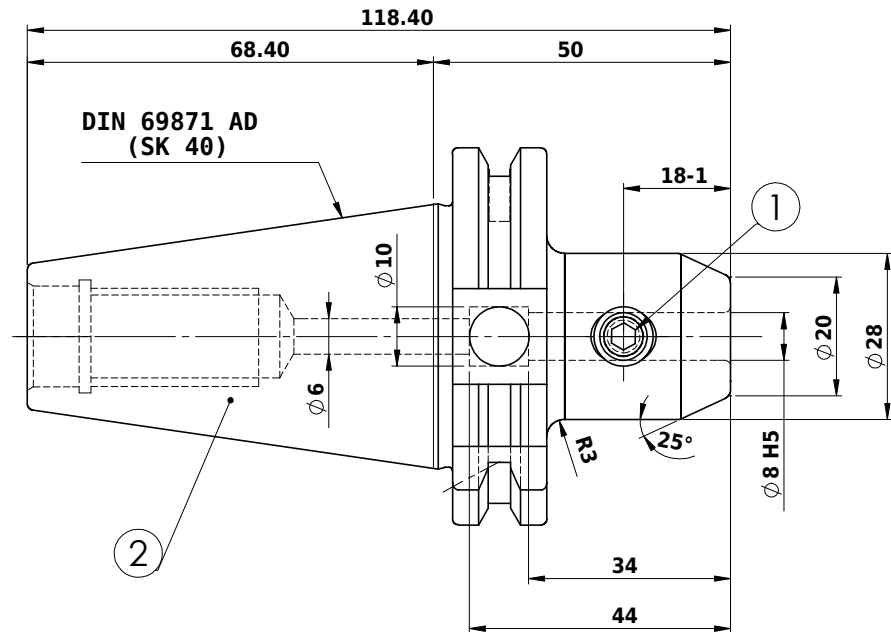
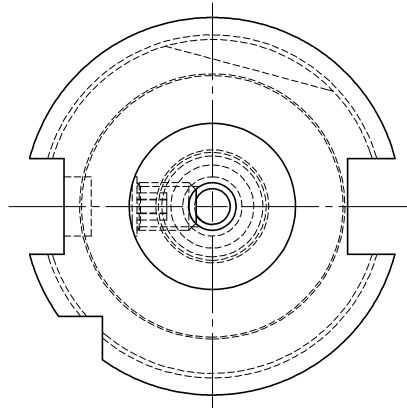

NOTE :

BALANCING G6.3 AT 15000 RPM

WEIGHT : 0.9 kg

MARKING : DIN 69871 AD SK40 WEØ8H50
G6.3 15000 U/MIN

ITEM NO.	PART NUMBER	DESCRIPTION	QTY.
1	GS-M8X10-DIN1835-B	GRUB SCREW-(B.O.)	1
2	FWS401A-EMH08050	SK40 EM 08 050WW	1

	μ m	0.012	0.025	0.05	0.1	0.2	0.4	0.8	1.6	3.2	6.3	12.5	25	50
GRADES		N1	N2	N3	N4	N5	N6	N7	N8	N9	N10	N11	N12	
SYMBOLS		▽	▽	▽	▽	▽	▽	▽	▽	▽	▽	▽	▽	~
TOLERANCE FREE DIMENSIONS TOLERANCE		2016		NAME		DATE								
		16MnCr5		DRAWN SVK		26/11								
Dimns.	Dia	Length	CHECKED RVL		26/11									
0.5 to 3	± 0.05	± 0.10	APPROVED											
3 to 6	± 0.10	± 0.15	SCALE : NTS		QTY. :									
6 to 30	± 0.15	± 0.20	PART NAME:				DRAWING No.				REV.			
30 to 120	± 0.20	± 0.25	END MILL HOLDER				FWS401A-EMH08050				00			
120 to 500	± 0.30	± 0.50												

WEMAG
2002263.0800