

1.9

Torusfräser, FORMAT GT, Alu

Ausführung: Mit Zentrumschnitt, zum Bohren geeignet. Oberfläche poliert.

Anwendung: Optimal für die HSC-Bearbeitung.

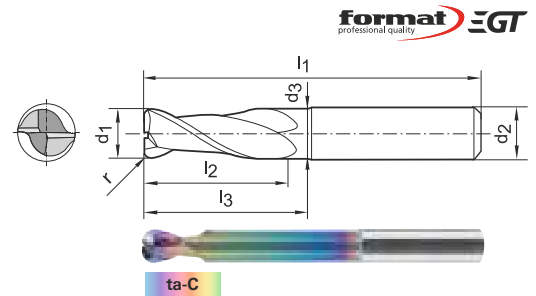
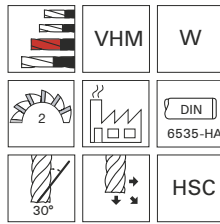

Einsatz	STAHL			INOX			GUSS		SOND.-LEG.	NE-METALLE			GEHÄRTETER STAHL			Bestell-Nr.	
V _c [m/min]	< 700 N/mm ²	< 1000 N/mm ²	< 1400 N/mm ²	ferrit./ martens.	austeni- tisch	Duplex	GG/ GTS	GGG	Titan > 850 N/mm ²	Alu < 8% Si	Alu > 8% Si	Kupfer/ Kupfer- Leg.	Graphit/ GFK/CFK/ Duropl.	< 55 HRC	< 60 HRC		> 60 HRC

Ø d ₁ mm	Eckenradius r mm	Halsfreischliff l ₃ mm	Hals-Ø d ₃ mm	Schneidenlänge l ₂ mm	Gesamtlänge l ₁ mm	Schaft-Ø d ₂ = h6 mm	format EG		Bestell-Nr.
							ALU < 8% Si	1940 ta-C	
3	0,3	32	2,9	4	75	6	f _z mm	€	...0300
4	0,3	36	3,9	5	75	6	0,01	62,80	...0400
5	0,3	40	4,9	6	75	6	0,017	69,60	...0500
6	0,3	44	5,8	7	80	6	0,02	76,90	...0600
6	1	44	5,8	7	80	6	0,03	82,90	...0601
6	2	44	5,8	7	80	6	0,03	82,90	...0602
8	0,3	54	7,8	9	100	8	0,04	116,50	...0800
8	1	54	7,8	9	100	8	0,04	116,50	...0801
8	2	54	7,8	9	100	8	0,04	116,50	...0802
10	0,3	60	9,7	11	100	10	0,05	157,00	...1000
10	1,5	60	9,7	11	100	10	0,05	157,00	...1001
10	3	60	9,7	11	100	10	0,05	157,00	...1002
12	1,5	75	11,7	13	120	12	0,07	209,00	...1200
12	4	75	11,7	13	120	12	0,07	209,00	...1201
16	2	92	15,7	17	150	16	0,09	353,00	...1600
16	5	92	15,7	17	150	16	0,09	353,00	...1601

(W201)

Torusfräser, FORMAT GT, Alu

Ausführung: Mit Zentrumschnitt, zum Bohren geeignet. Oberfläche poliert.

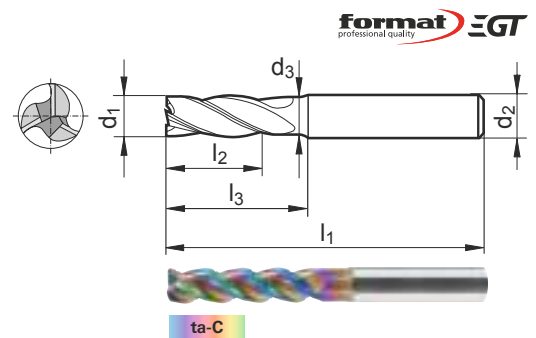
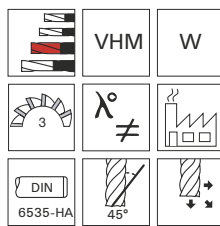

Einsatz	STAHL			INOX			GUSS		SOND.-LEG.	NE-METALLE			GEHÄRTETER STAHL			Bestell-Nr.	
V _c [m/min]	< 700 N/mm ²	< 1000 N/mm ²	< 1400 N/mm ²	ferrit./ martens.	austeni- tisch	Duplex	GG/ GTS	GGG	Titan > 850 N/mm ²	Alu < 8% Si	Alu > 8% Si	Kupfer/ Kupfer- Leg.	Graphit/ GFK/CFK/ Duropl.	< 55 HRC	< 60 HRC		> 60 HRC

Ø d ₁ mm	Eckenradius r mm	Halsfreischliff l ₃ mm	Hals-Ø d ₃ mm	Schneidenlänge l ₂ mm	Gesamtlänge l ₁ mm	Schaft-Ø d ₂ = h6 mm	format EG		Bestell-Nr.
							ALU < 8% Si	1941 ta-C	
3	0,5	31	5,8	25	71	6	f _z mm	€	...0300
3	1	31	5,8	25	71	6	0,07	70,20	...0301

(W201)

Fortsetzung nächste Seite