

All Dimensions are in MM

Rev.No.	Ch.Let	Alterations	Date	Sign.	Appd.

For Customer Approval

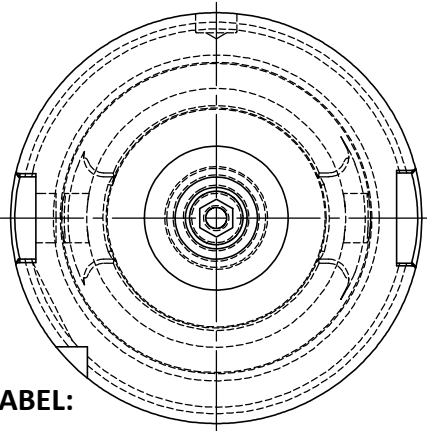
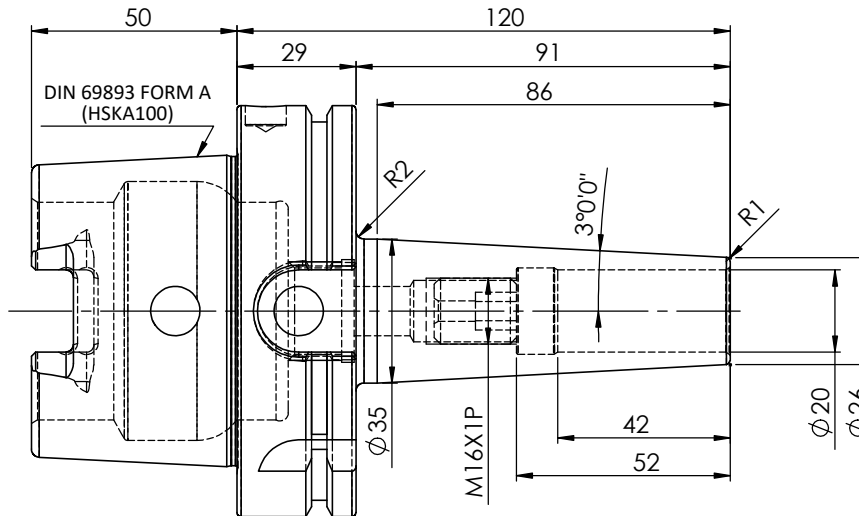
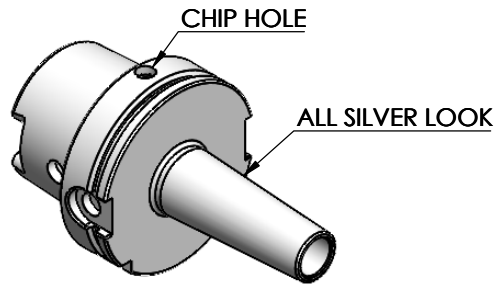

LABEL:

**2002388.2001
 SCHRUMPFUTTER SCHLANK 3°
 SHRINK FIT HOLDER SLIM 3°
 DIN 69893 HSK100A
 SRS 20mm X 120mm
 G2.5/25000 U/MIN**

**MARKING: DIN 69893 A HSK100A SFHS20 H120
 G2.5 25000 U/MIN**

Notes	
Balancing Value	G2.5 @25000 RPM
Approx Weight	2.40Kg

	µ m	0.012	0.025	0.05	0.1	0.2	0.4	0.8	1.6	3.2	6.3	12.5	25	50
GRADES		N1	N2	N3	N4	N5	N6	N7	N8	N9	N10	N11	N12	
SYMBOLS		▽▽▽	▽▽	▽	▽	▽	▽	▽	▽	▽	▽	▽	▽	~
TOLERANCE FREE DIMENSIONS TOLERANCE		MATERIALS: HDS		2024	NAME	DATE	2002388.2001							
Dimns.	Dia	Length		DRAWN	YSK	03/09								
0.5 to 3	± 0.05	± 0.10		CHECKED	RVL	03/09								
3 to 6	± 0.10	± 0.15		APPROVED										
6 to 30	± 0.15	± 0.20		SCALE: NTS	QTY.:		PART NAME:		DRAWING No.					REV.
30 to 120	± 0.20	± 0.25					HSKA100SFS20120WW		FWA100H-SFS20120					00
120 to 500	± 0.30	± 0.50												

ITEM NO.	PART NUMBER	DESCRIPTION	QTY.
2	SCWM16x1x20	STOPPER SCREW	1
1	FWA100H-SFS20120	HSKA100SFS20120WW	1