

All Dimensions are in MM

Rev.No.	Ch.Let	Alterations	Date	Sign.	Appd.

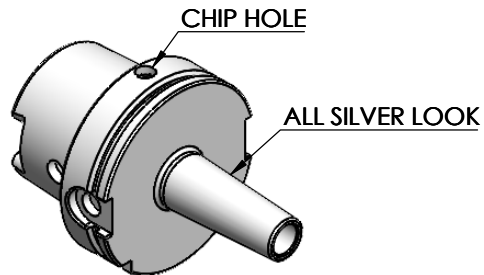

For Customer Approval

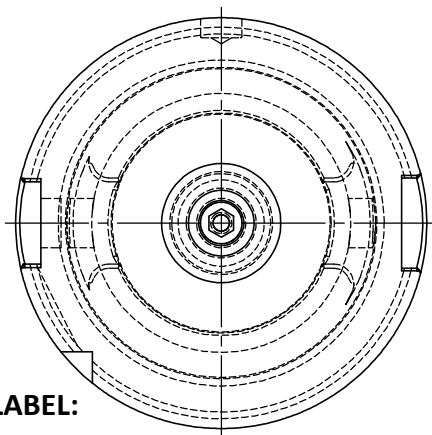

LABEL:

**2002388.1600
 SCHRUMPFUTTER SCHLANK 3°
 SHRINK FIT HOLDER SLIM 3°
 DIN 69893 HSK100A
 SRS 16mm X 100mm
 G2.5/25000 U/MIN**

**MARKING: DIN 69893 A HSK100A SFHS16 H100
 G2.5 25000 U/MIN**

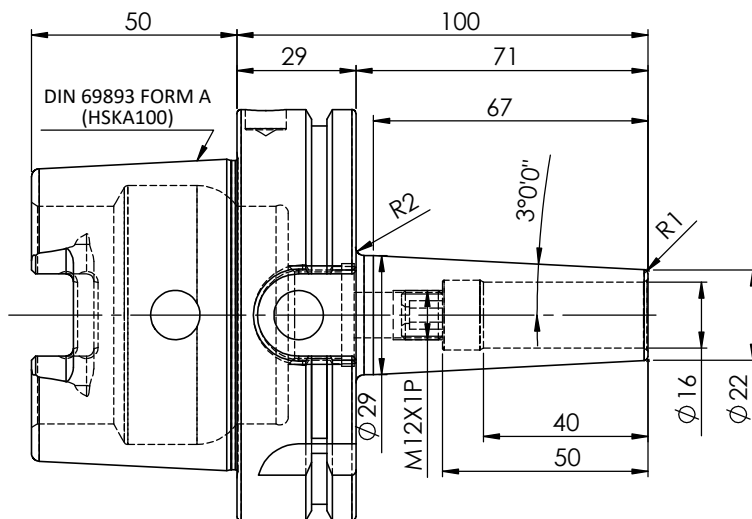

Notes	
Balancing Value	G2.5 @25000 RPM
Approx Weight	2.20Kg

	μ m	0.012	0.025	0.05	0.1	0.2	0.4	0.8	1.6	3.2	6.3	12.5	25	50
GRADES		N1	N2	N3	N4	N5	N6	N7	N8	N9	N10	N11	N12	
SYMBOLS		▽▽▽	▽▽	▽	▽	▽	▽	▽	▽	▽	▽	▽	▽	~
TOLERANCE FREE DIMENSIONS TOLERANCE		MATERIALS: HDS		2024	NAME	DATE	2002388.1600							
Dimns.	Dia	Length	DRAWN	YSK	03/09									
0.5 to 3	± 0.05	± 0.10	CHECKED	RVL	03/09									
3 to 6	± 0.10	± 0.15	APPROVED											
6 to 30	± 0.15	± 0.20	SCALE: NTS	QTY.:			PART NAME:		DRAWING No.		REV.			
30 to 120	± 0.20	± 0.25	HSKA100SFS16100WW		FWA100H-SFS16100						00			
120 to 500	± 0.30	± 0.50												

ITEM NO.	PART NUMBER	DESCRIPTION	QTY.
2	SCWM12X1-10	STOPPER SCREW	1
1	FWA100H-SFS16100	HSKA100SFS16100WW	1