

Rev.No.	Ch.Let	Alterations	Date	Sign.	Appd.

All Dimensions are in MM

For Customer Approval

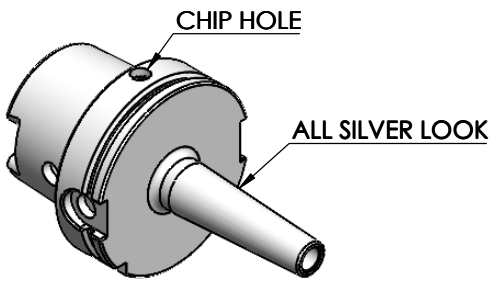

A

B

C

D

E

F

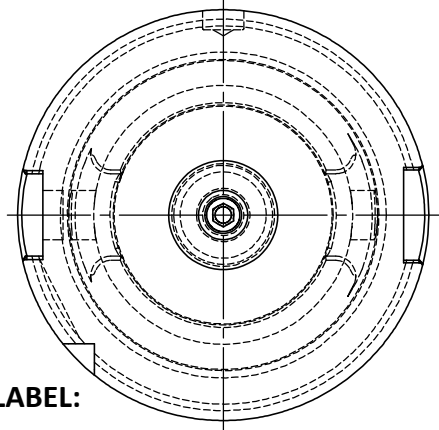

LABEL:

**2002388.1201
 SCHRUMPFUTTER SCHLANK 3°
 SHRINK FIT HOLDER SLIM 3°
 DIN 69893 HSK100A
 SRS 12mm X 120mm
 G2.5/25000 U/MIN**

**MARKING: DIN 69893 A HSK100A SFHS12 H120
 G2.5 25000 U/MIN**

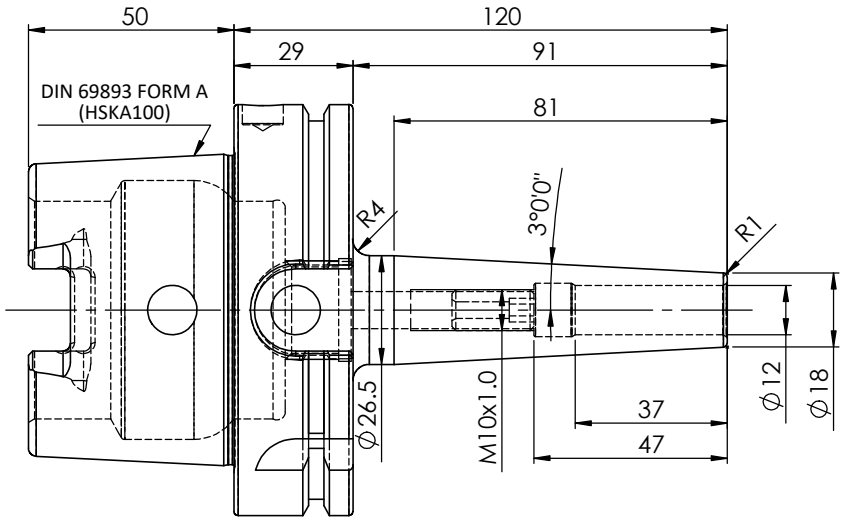

Notes	
Balancing Value	G2.5 @25000 RPM
Approx Weight	2.10Kg

μ m	0.012	0.025	0.05	0.1	0.2	0.4	0.8	1.6	3.2	6.3	12.5	25	50
GRADES	N1	N2	N3	N4	N5	N6	N7	N8	N9	N10	N11	N12	
SYMBOLS	▽▽▽	▽▽▽	▽▽▽	▽▽▽	▽▽▽	▽▽▽	▽▽▽	▽▽▽	▽▽▽	▽▽▽	▽▽▽	▽▽▽	~
TOLERANCE FREE DIMENSIONS TOLERANCE	MATERIALS: HDS			2024	NAME	DATE	2002388.1201						
Dimns.	Dia	Length	DRAWN	YSK	03/09								
0.5 to 3	± 0.05	± 0.10	CHECKED	RVL	03/09								
3 to 6	± 0.10	± 0.15	APPROVED										
6 to 30	± 0.15	± 0.20	SCALE: NTS	QTY.:	PART NAME:			DRAWING No.					REV.
30 to 120	± 0.20	± 0.25	HSKA100SFS12120WW			FWA100H-SFS12120					00		
120 to 500	± 0.30	± 0.50											

ITEM NO.	PART NUMBER	DESCRIPTION	QTY.
2	SCWM10x1x20	STOPPER SCREW	1
1	FWA100H-SFS12120	HSKA100SFS12120WW	1