

Rev.No.	Ch.Let	Alterations	Date	Sign.	Appd.

All Dimensions are in MM

For Customer Approval

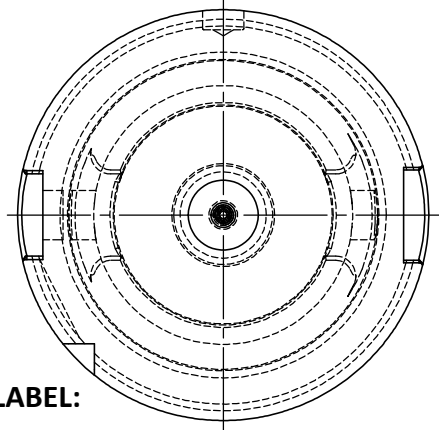
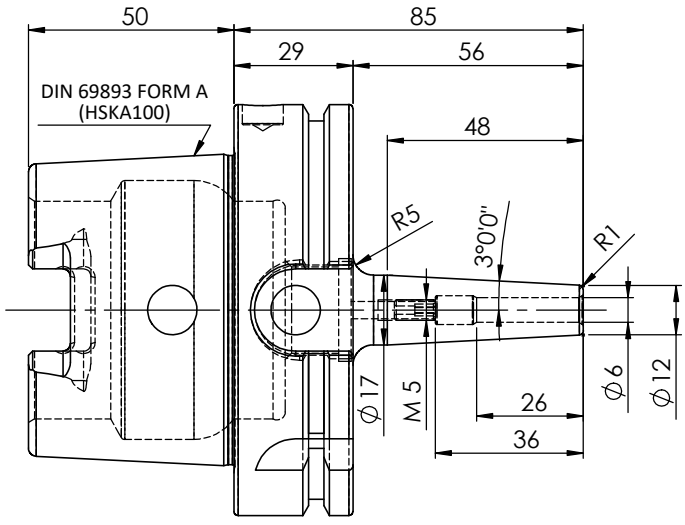
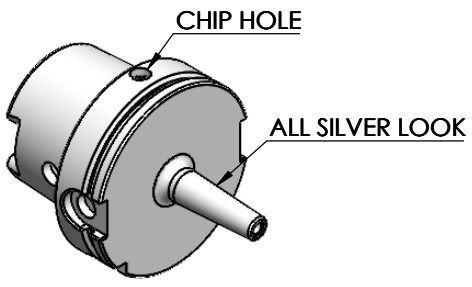

LABEL:

2002388.0600
SCHRUMPFUTTER SCHLANK 3°
SHRINK FIT HOLDER SLIM 3°
DIN 69893 HSK100A
SRS 06mm X 085mm
G2.5/25000 U/MIN

MARKING: DIN 69893 A HSK100A SFHS06 H085
G2.5 25000 U/MIN

Notes	
Balancing Value	G2.5 @25000 RPM
Approx Weight	2.10Kg

	μ m	0.012	0.025	0.05	0.1	0.2	0.4	0.8	1.6	3.2	6.3	12.5	25	50
GRADES		N1	N2	N3	N4	N5	N6	N7	N8	N9	N10	N11	N12	
SYMBOLS		▽▽▽	▽▽	▽	▽	▽	▽	▽	▽	▽	▽	▽	▽	~
TOLERANCE FREE DIMENSIONS TOLERANCE		MATERIALS: HDS			2024	NAME	DATE	2002388.0600						
Dimns.	Dia	Length		DRAWN	YSK	03/09								
0.5 to 3	± 0.05	± 0.10		CHECKED	RVL	03/09								
3 to 6	± 0.10	± 0.15		APPROVED										
6 to 30	± 0.15	± 0.20		SCALE: NTS	QTY.:		PART NAME:		DRAWING No.			REV.		
30 to 120	± 0.20	± 0.25		HSKA100SFS06085WW			FWA100H-SFS06085			00				
120 to 500	± 0.30	± 0.50												

ITEM NO.	PART NUMBER	DESCRIPTION	QTY.
2	SCWM5x10	STOPPER SCREW (B.O.)	1
1	FWA100H-SFS06085	HSKA100SFS06085WW	1