

**All Dimensions are in MM**

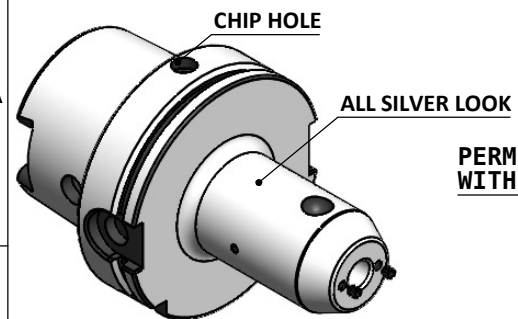

PERMNET SEALING WITH LOCTITE

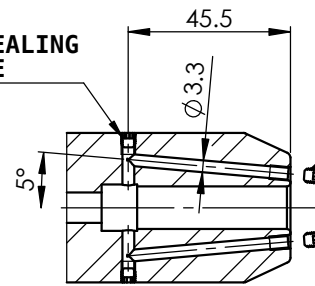

SCREWS TO BE PACKED SEPERATELY IN PLASTIC POUCH WITH LABEL & PUT INTO WELDON BORE & THEN SEAL THE HOLDER WITH COVER

LABEL FOR PLASTIC BAGS:  
Verschlusschraube  
Grub Screw  
M4 X 4mm x 2 mm

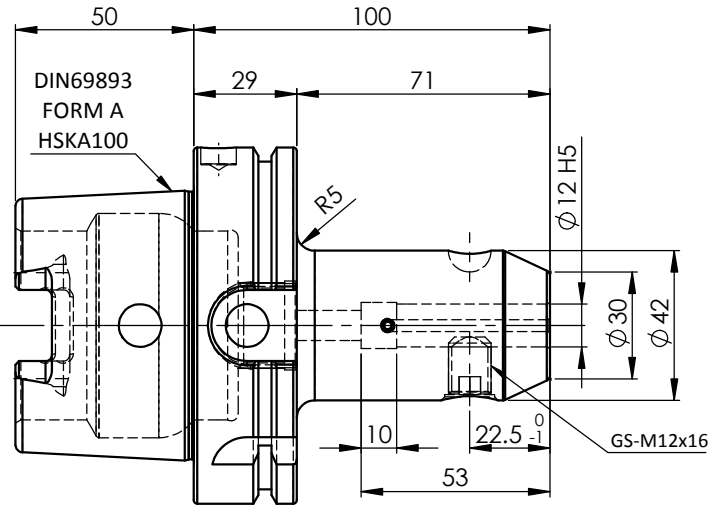
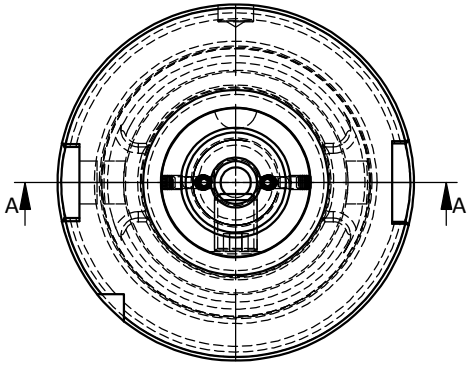

**LABEL :**  
2002379.1200  
WELDON-AUFNAHME MIT KK  
WELD.HOLDER COOL.CHANNEL  
DIN69893 HSK100A  
WK 12 mm x 100 mm  
G2.5 25000 U/MIN

**MARKING : DIN 69893 A HSK100A WK12 H100  
G2.5 25000 U/MIN**

**NOTE :**  
BALANCING 2.5G AT 25000 RPM

**WEIGHT : 2.6 Kg**

		µ m	0.012	0.025	0.05	0.1	0.2	0.4	0.8	1.6	3.2	6.3	12.5	25	50
		GRADES	N1	N2	N3	N4	N5	N6	N7	N8	N9	N10	N11	N12	
		SYMBOLS	▽▽▽			▽▽▽			▽▽▽			▽			~
TOLERANCE		MATERIALS:		2015	NAME		DATE		2002379.1200						
FREE DIMENSIONS		16Mncr5		DRAWN	ELA		18/5								
TOLERANCE				CHECKED	RVL		18/5								
				APPROVED											
Dimns.	Dia	Length	PART NAME:		DRAWING No.		REV.								
0.5 to 3	± 0.05	± 0.10	HSKA100EK12100WW		FWA100H-EKH12100		02								
3 to 6	± 0.10	± 0.15													
6 to 30	± 0.15	± 0.20													
30 to 120	± 0.20	± 0.25													
120 to 500	± 0.30	± 0.50													

ITEM NO.	PART NUMBER	DESCRIPTION	QTY
1	FWA100H-EKH12100	HSKA100EK12100WW	1
2	GS-M12X16-DIN1835-B	GRUB SCREW (B.O.)	1
3	GS-M4X4	GRUB SCREW	4