

Rev.No.	Ch.Let	Alterations	Date	Sign.	Appd.

All Dimensions are in MM

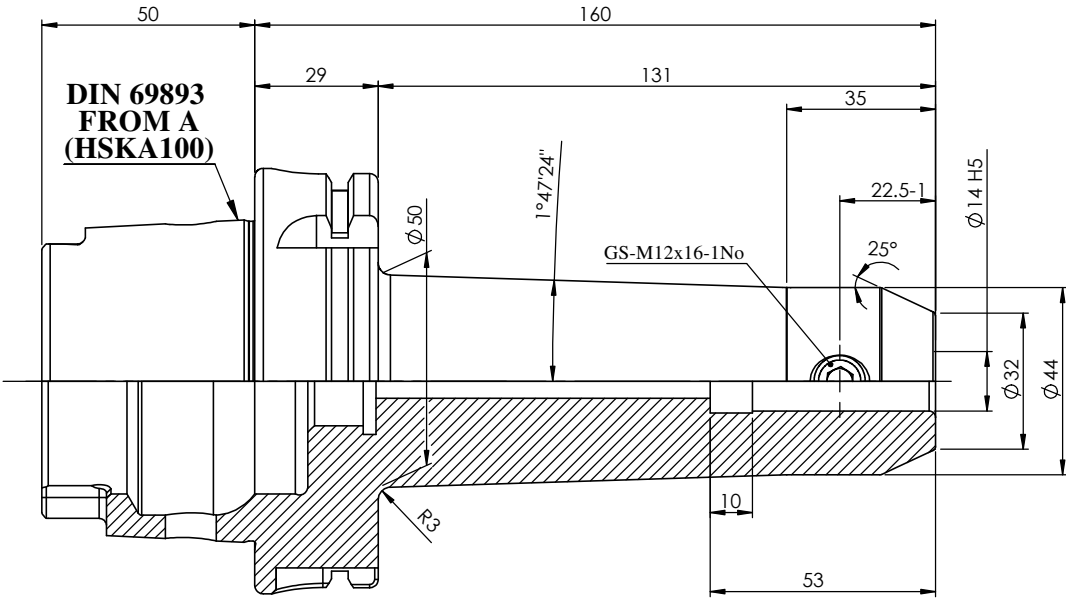
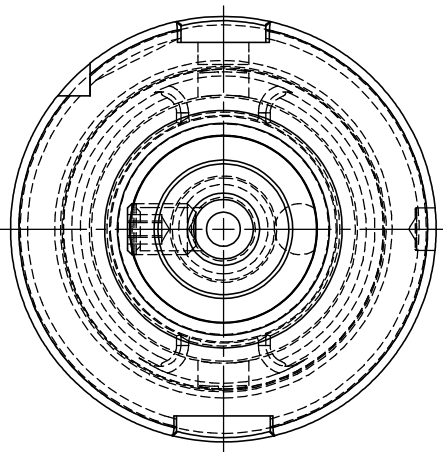
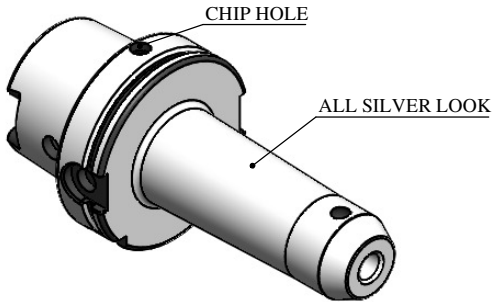

LABEL :
91100A-WE814160
WELDON-AUFNAHME
WELDON HOLDER
DIN69893 HSK100A
WE 14 mm x 160 mm
G2,5 25.000 U / MIN

MARKING : DIN 69893 A HSK100A WE14 H160
G2.5 25000 U/MIN

NOTE :
BALANCING 2.5G AT 25000 RPM
WEIGHT : 3.5 Kg

ITEM NO.	PART NUMBER	DESCRIPTION	QTY.
1	FWA100H-EMH14160	HSKA100EM14160WW	1
2	GS-M12X16	GRUB SCREW	1

µm	0.012	0.025	0.05	0.1	0.2	0.4	0.8	1.6	3.2	6.3	12.5	25	50
GRADES	N1	N2	N3	N4	N5	N6	N7	N8	N9	N10	N11	N12	
SYMBOLS	▽▽▽▽	▽▽▽	▽▽	▽	~								
TOLERANCE FREE DIMENSIONS TOLERANCE	MATERIALS: 16MnCr5		2015	NAME	DATE	91100A-WE814160							
Dimns. Dia Length	DRAWN <i>MLCP</i>		29/06	CHECKED <i>RVL</i>		DRAWING No. FWA100H-EMH14160							
0.5 to 3 ±0.05 ±0.10	APPROVED		29/06	SCALE : NTS QTY. :		REV. 00							
3 to 6 ±0.10 ±0.15	PART NAME: HSK 100EM 14160WW												
6 to 30 ±0.15 ±0.20													
30 to 120 ±0.20 ±0.25													
120 to 500 ±0.30 ±0.50													