

All Dimensions are in MM

Rev.No.	Ch.Let	Alterations	Date	Sign.	Appd.

For Customer Approval

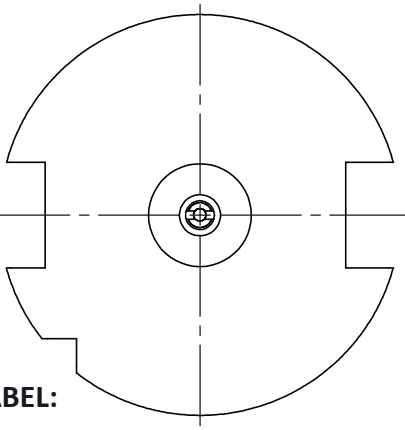
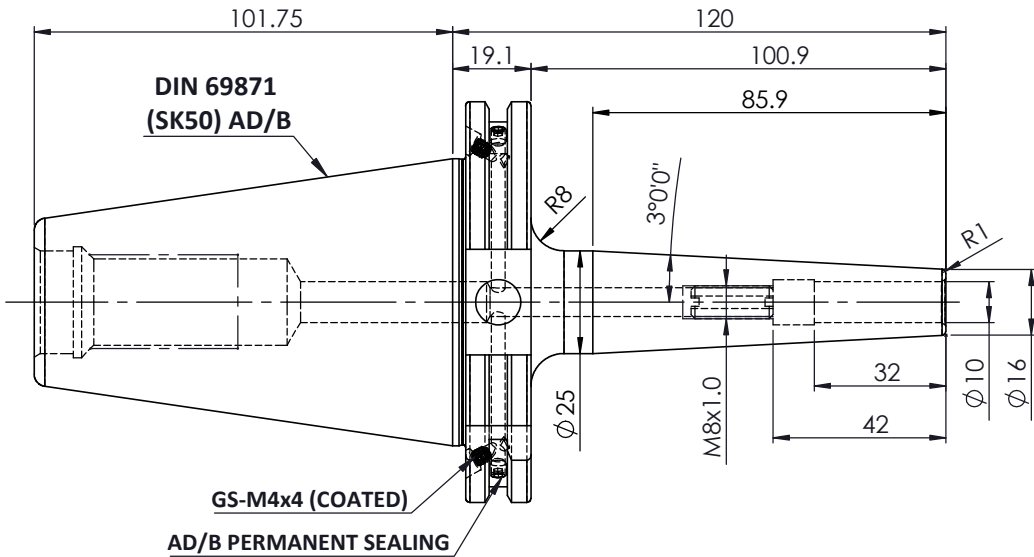
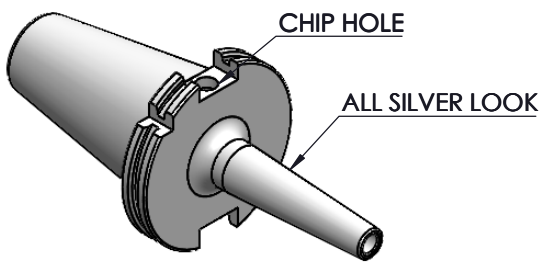

LABEL:

2002375.1001
SCHRUMPFUTTER SCHLANK 3°
SHRINK FIT HOLDER SLIM 3°
ISO 7388-1 (DIN69871) SK50 AD/AF (AD+B)
SRS2 10mm X 120mm
G2.5/25000 U/MIN

MARKING: ISO 7388-1 (DIN69871) SK50 AD/AF (AD+B) SFHS10 H120
G2.5 25000 U/MIN

ITEM NO.	PART NUMBER	DESCRIPTION	QTY.
4	SCWM8x1X20	STOPPER SCREW	1
3	GS-M4X4 COATED	GRUB SCREW	2
2	GS-M4X4	GRUB SCREW-(B.O)	2
1	FWS509H-SFS10120	SK50SFS10120FWW	1

Notes	
Balancing Value	G2.5 @ 25000 RPM
Approx Weight	2.8Kg

TOLERANCE	FREE DIMENSIONS	TOLERANCE	Dimns.	Dia	Length	GRADES											
						µ m	0.012	0.025	0.05	0.1	0.2	0.4	0.8	1.6	3.2	6.3	12.5
						N1	N2	N3	N4	N5	N6	N7	N8	N9	N10	N11	N12
						SYMBOLS						▽▽▽	▽▽	▽	~		
TOLERANCE			MATERIALS:			2024	NAME	DATE	2002375.1001								
FREE DIMENSIONS			HDS			DRAWN	YSK	30/08									
TOLERANCE						CHECKED	RVL	30/08									
						APPROVED											
SCALE: NTS			QTY.:			PART NAME:		DRAWING No.		REV.							
						SK50SFS10120FWW		FWS509H-SFS10120		00							