

All Dimensions are in MM

Rev.No	Ch.Let	Alterations	Date	Sign.	Appd.

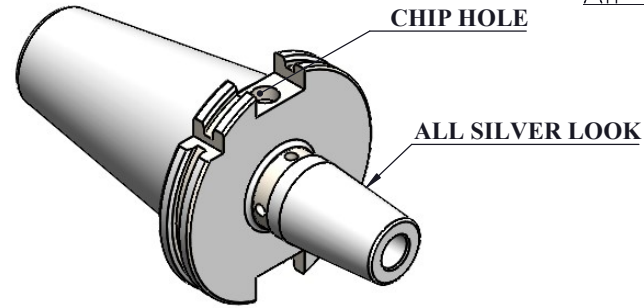

For Customer Approval

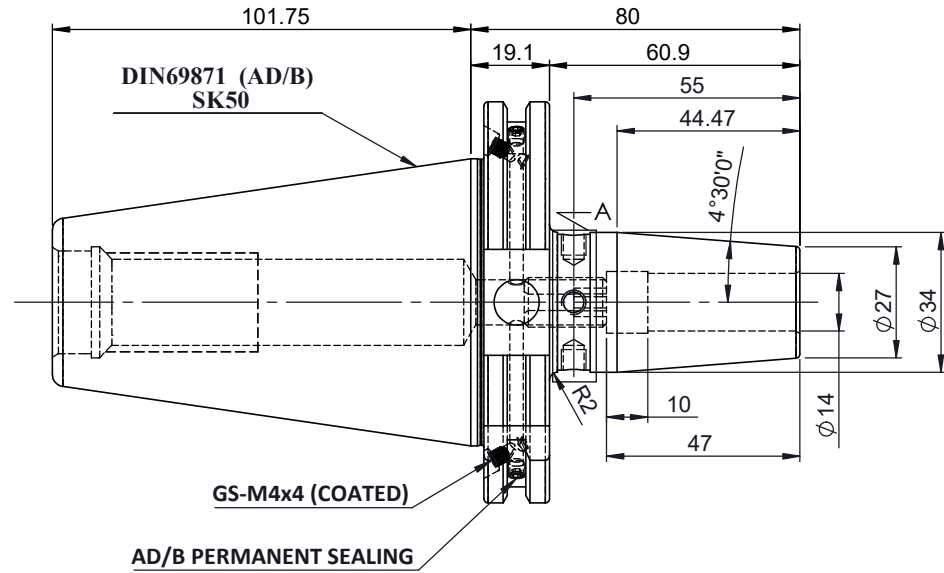
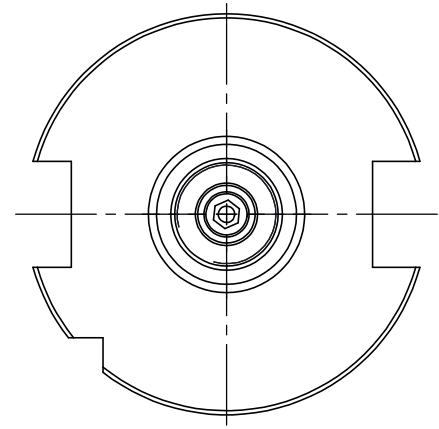
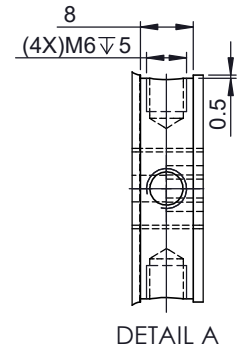

LABEL :

2002373.1400
SCHRUMPFUTTER
SHRINK FIT HOLDER
ISO 7388-1 (DIN69871) SK50 AD/AF (AD+B)
SR2 14mm X 080mm
G2,5/25000 U/MIN

MARKING : ISO 7388-1 (DIN69871) SK50 AD/AF (AD+B) SR14 H080
G2,5/25000 U/MIN

Notes	
Balancing Value	G2.5 @25000RPM
Approx Weight	2.8Kg

	μ m	0.012	0.025	0.05	0.1	0.2	0.4	0.8	1.6	3.2	6.3	12.5	25	50
GRADES		N1	N2	N3	N4	N5	N6	N7	N8	N9	N10	N11	N12	
SYMBOLS		▽▽▽	▽▽	▽	▽	▽	▽	▽	▽	▽	▽	▽	▽	~
TOLERANCE	MATERIALS:	2024		NAME		DATE		2002373.1400						
FREE DIMENSIONS	HDS	DRAWN		SVR		26/03								
TOLERANCE		CHECKED		RVL		26/03								
		APPROVED												
Dimns.	Dia	Length	SCALE : NTS		QTY. :		PART NAME:							
0.5 to 3	±0.05	±0.10	SK50SFC 14080F		DRAWING No.		F1S509H-SFC 14080							
3 to 6	±0.10	±0.15			REV.		00							
6 to 30	±0.15	±0.20												
30 to 120	±0.20	±0.25												
120 to 500	±0.30	±0.50												

ITEM NO.	PART NUMBER	DESCRIPTION	QTY.
4	SCWM12X1X20	STOPPER SCREW	1
3	GS-M4X4 COATED	GRUB SCREW	2
2	GS-M4X4	GRUB SCREW-(B.O)	2
1	F1S509H-SFC14080	SK40SFC14080FWW	1