

**All Dimensions are in MM**

Rev.No.	Ch.Let	Alterations	Date	Sign.	Appd.

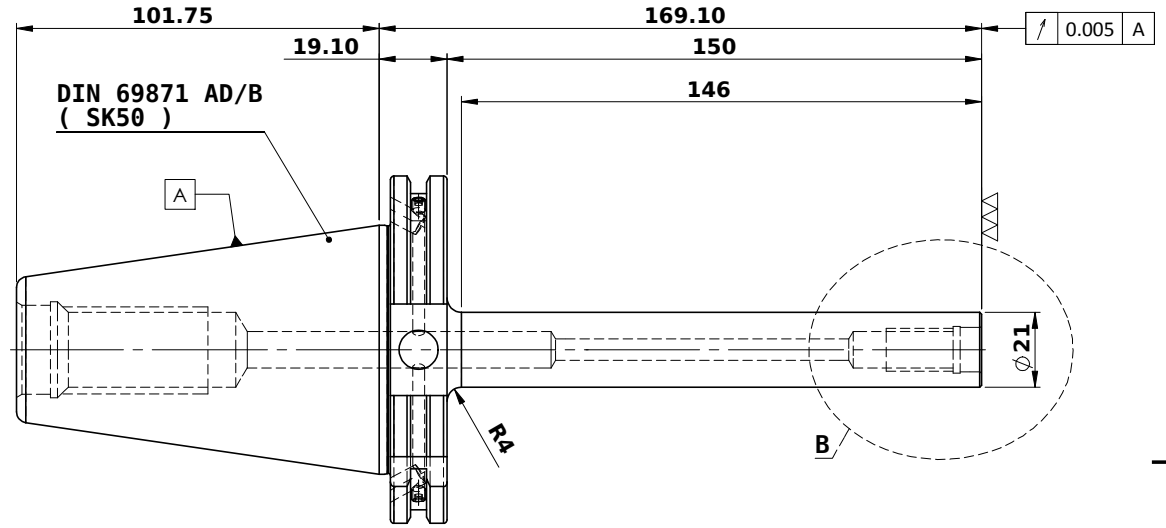
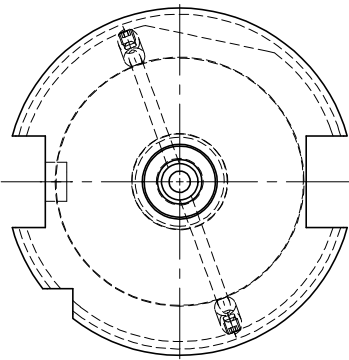
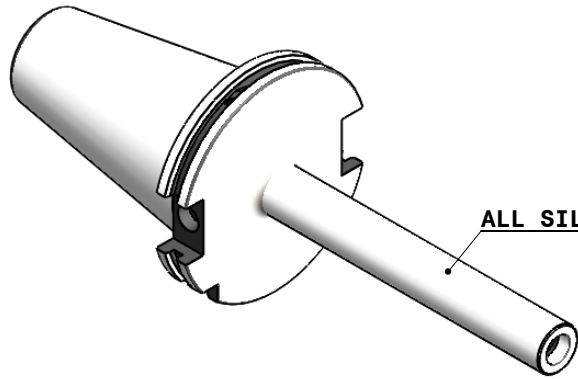

LABEL: -

2002372.1202  
 EINSCHRAUBFRÄSERAUFNAHME  
 SCREW-ON HOLDER  
 DIN69871 SK50 ADB  
 ESS M12 x 150 mm x 169 mm  
 G2,5 / 25000

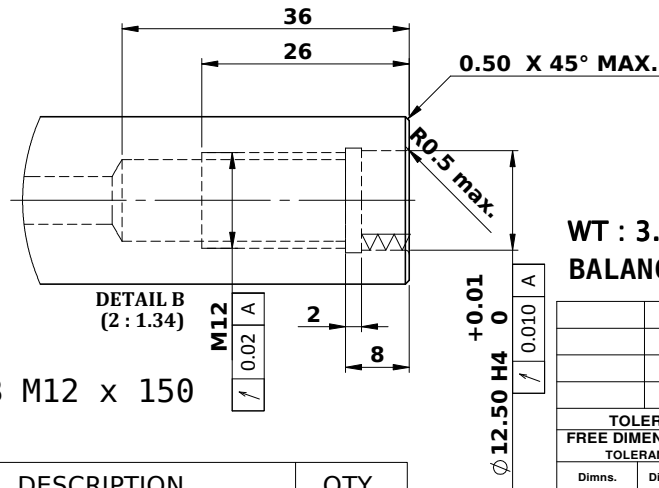

MARKING: - DIN 69871 SK50 AD&B M12 x 150  
 G2,5 25000

WT : 3.0 KG  
 BALANCING 2.5 G @ 25000 RPM

ITEM NO.	PART NUMBER	DESCRIPTION	QTY.
1	SK50TMS12169FWW	THREAD MILL HOLDER	1
2	GS-M4X4	GRUB SCREW-(B.O.)	2

Dimns.	Dia	Length	μ m	0.012	0.025	0.05	0.1	0.2	0.4	0.8	1.6	3.2	6.3	12.5	25	50
0.5 to 3	± 0.05	± 0.10		✓	✓	✓	✓	✓	✓	✓	✓	✓	✓	✓	✓	✓
3 to 6	± 0.10	± 0.15														
6 to 30	± 0.15	± 0.20														
30 to 120	± 0.20	± 0.25														
120 to 500	± 0.30	± 0.50														

GRADES	N1	N2	N3	N4	N5	N6	N7	N8	N9	N10	N11	N12

SYMBOLS	▽▽▽	▽▽	▽	~

TOLERANCE	MATERIALS:	2015	NAME	DATE
FREE DIMENSIONS	16MnCr5	DRAWN	SVK	19/07
TOLERANCE		CHECKED	RVL	19/07
		APPROVED		

SCALE : NTS QTY. :

PART NAME: SK50TMS12169FWW

DRAWING No. FWS09H-TMS12169

REV. 00

2002372.1202