

All Dimensions are in MM

Rev.No.	Ch.Let	Alterations	Date	Sign.	Appd.

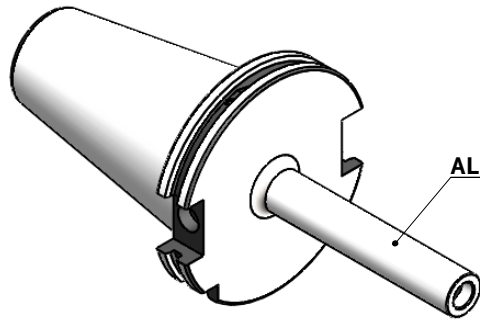

ALL SILVER LOOK

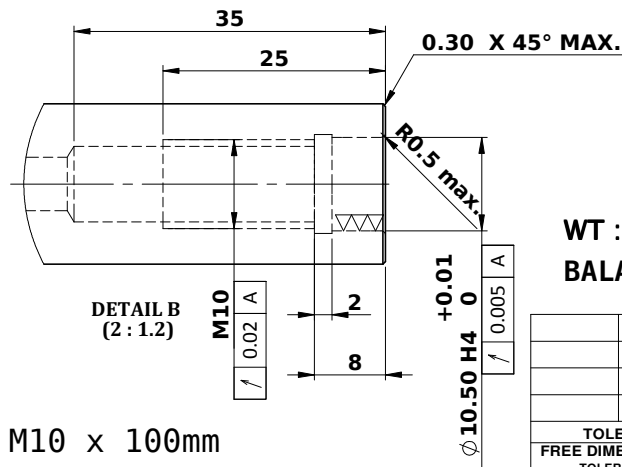
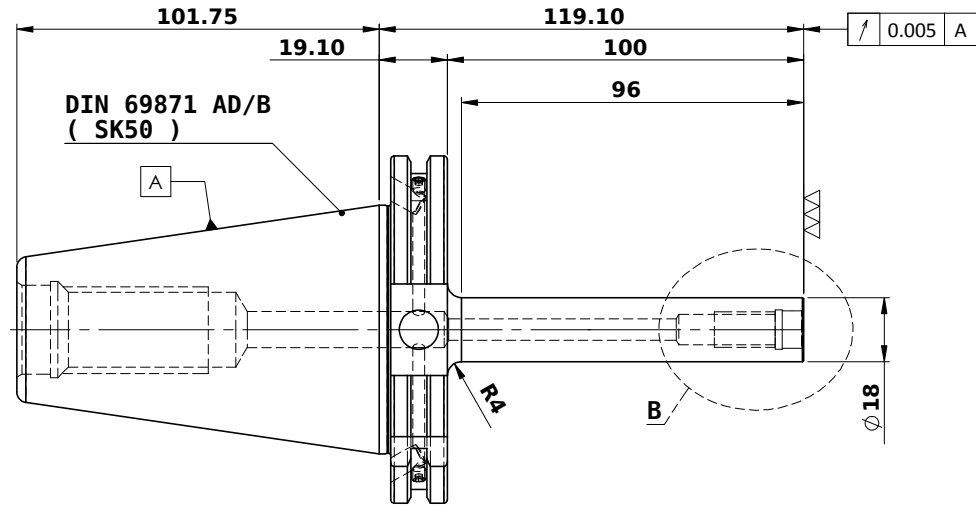
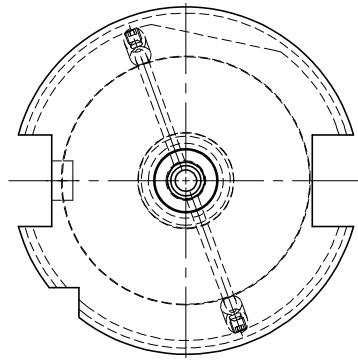

LABEL :-

2002372.1001
 EINSCHRAUBFRÄSERAUFNAHME
 SCREW-ON HOLDER ZYL/CYL
 DIN69871 SK50 ADB
 ESS M10 x 100 mm x 119 mm
 G2,5 / 25000

MARKING:- DIN 69871 SK50 AD&B M10 x 100mm
 G2,5 25000

WT : 2.5 KG
 BALANCING 2.5 G @ 25000 RPM

ITEM NO.	DESCRIPTION	PART NUMBER	QTY.
1	SK50TMS10119FWW	FWS509H-TMS10119	1
2	GRUB SCREW-(B.O.)	GS-M4X4	2

μm	0.012	0.025	0.05	0.1	0.2	0.4	0.8	1.6	3.2	6.3	12.5	25	50
GRADES	N1	N2	N3	N4	N5	N6	N7	N8	N9	N10	N11	N12	
SYMBOLS	▽▽▽			▽▽			▽			~			
TOLERANCE FREE DIMENSIONS	MATERIALS:		2015	NAME		DATE		2002372.1001					
TOLERANCE	16MnCr5		DRAWN	SVK		19/07							
Dimns.	Dia	Length	CHECKED	RVL		19/07							
0.5 to 3	± 0.05	± 0.10	APPROVED										
3 to 6	± 0.10	± 0.15	SCALE : NTS		QTY. :								
6 to 30	± 0.15	± 0.20	PART NAME:			DRAWING No.			REV.				
30 to 120	± 0.20	± 0.25	SK50TMS10119FWW			FWS509H-TMS10119			00				
120 to 500	± 0.30	± 0.50											