

Rev.No.	Ch.Let	Alterations	Date	Sign.	Appd.

All Dimensions are in MM

ALL SILVER LOOK

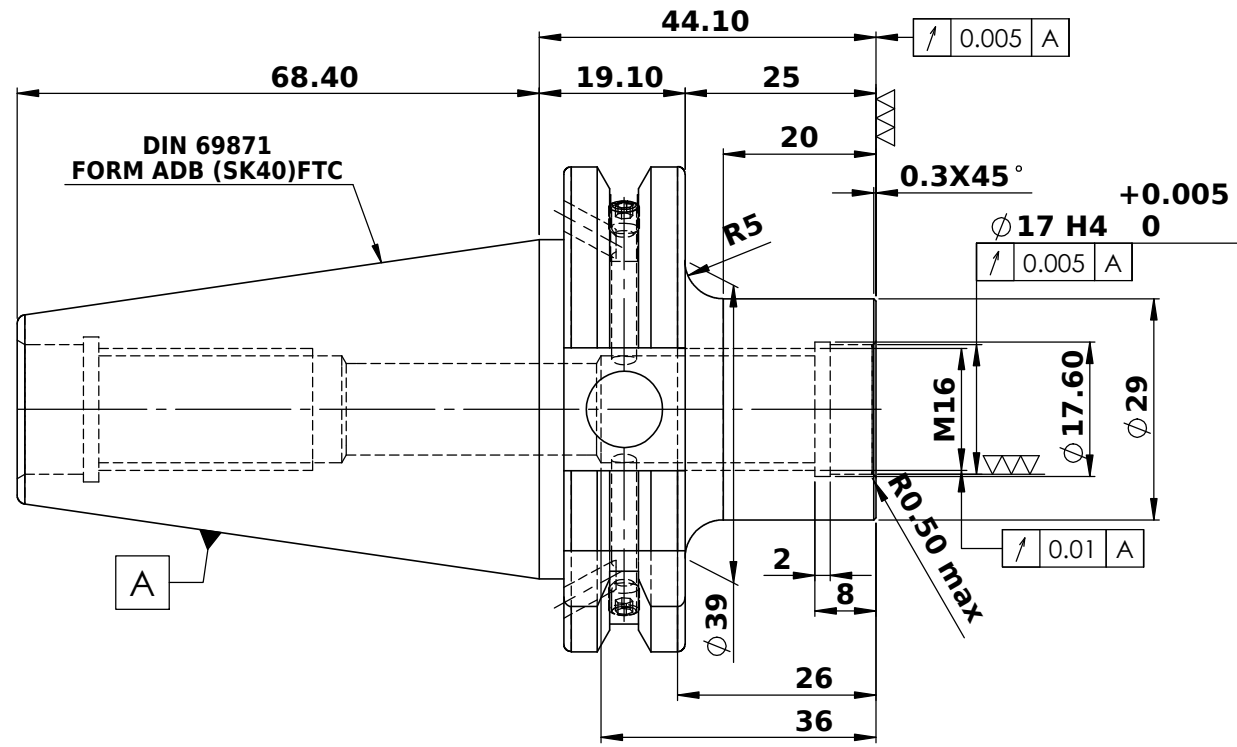
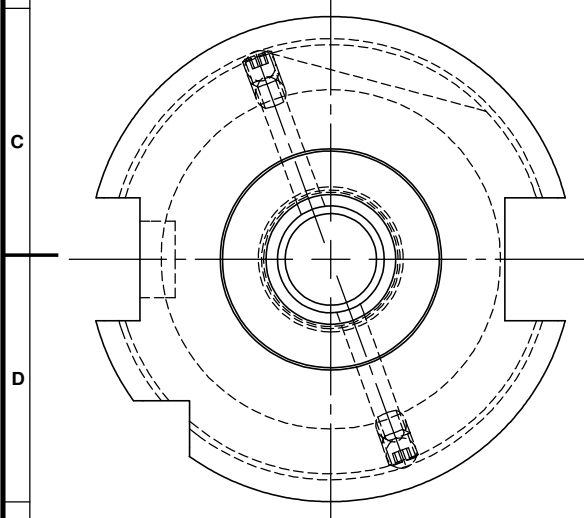
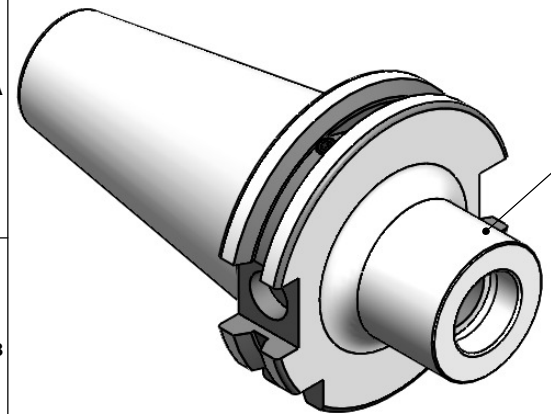

LABEL :-
2002369.1604
EINSCHRAUBFRÄSERAUFNAHME
SCREW-ON HOLDER
DIN 69871 AD&B SK40
ES M16 x 025 mm x 044 mm
G2,5 / 25000

BALANCING 2.5G 25000 RPM
WEIGHT :- 1.1 Kg.

MARKING:- DIN 69871 AD&B SK40 M16 x 025mm
G2,5 25000

μm	0.012	0.025	0.05	0.1	0.2	0.4	0.8	1.6	3.2	6.3	12.5	25	50
GRADES	N1	N2	N3	N4	N5	N6	N7	N8	N9	N10	N11	N12	
SYMBOLS	▽▽▽			▽▽▽			▽▽			▽			~

TOLERANCE	MATERIALS:	2020	NAME	DATE	2002369.1604
FREE DIMENSIONS	16MnCr5	DRAWN	PGK	26/06	
TOLERANCE	CHECKED	RVL	26/06		
	APPROVED				
Dimns.	Dia	Length	SCALE : NTS QTY. :		DRAWING No. FWS409H-TMH16044
0.5 to 3	± 0.05	± 0.10			
3 to 6	± 0.10	± 0.15			
6 to 30	± 0.15	± 0.20			
30 to 120	± 0.20	± 0.25			
120 to 500	± 0.30	± 0.50	PART NAME: SK40TMH16044FWW		REV. 00

ITEM NO.	PART NUMBER	DESCRIPTION	QTY.
1	FWS409H-TMH16044	SK40TMH16044FWW	1
2	GS-M4X4	GRUB SCREW-(B.O.)	2

