

Rev.No.	Ch.Let	Alterations	Date	Sign.	Appd.

All Dimensions are in MM

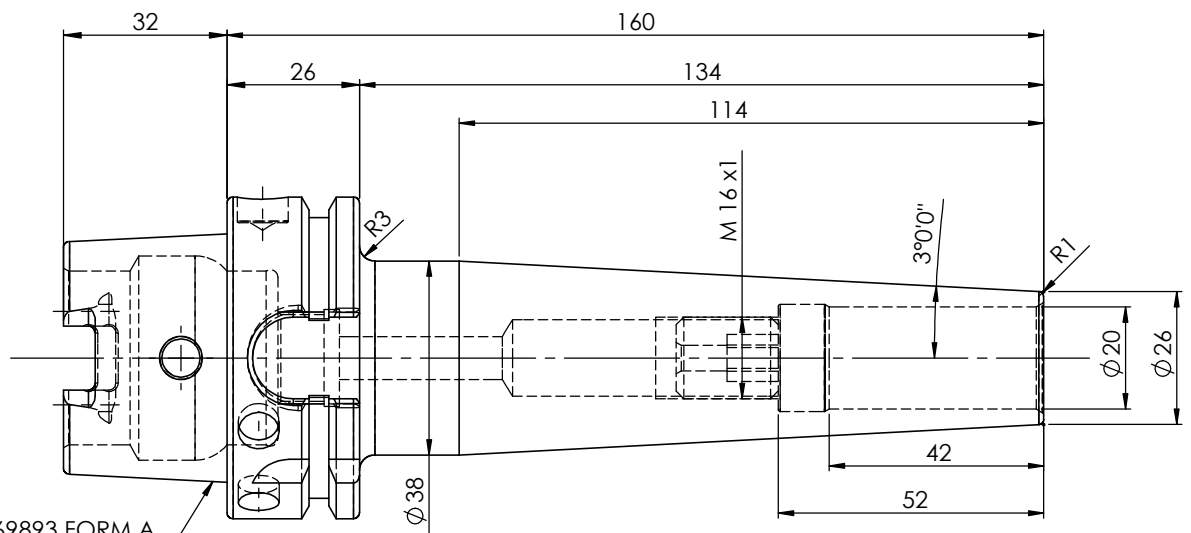
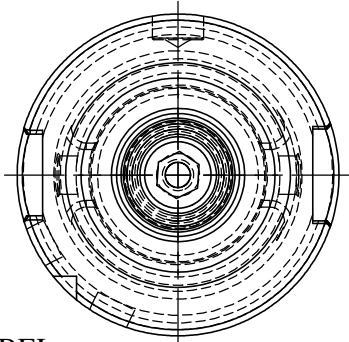
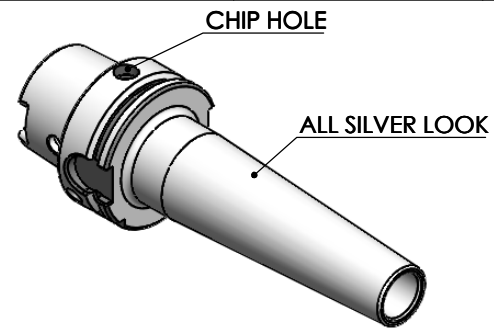

LABEL:

DIN 69893 FORM A (HKA63)

2002275.2002
 SCHRUMPFUTTER SCHLANK 3°
 SHRINK FIT HOLDER SLIM 3°
 DIN 69893 HSK063A
 SRS 20mm X 160mm
 G2.5/25000 U/MIN

MARKING: DIN 69893 A HSK63A SFHS20 H160
 G2.5 25000 U/MIN

NOTE:

BALANCING : 2.5G @ 25000RPM

WEIGHT : 1.3 Kg

µm	0.012	0.025	0.05	0.1	0.2	0.4	0.8	1.6	3.2	6.3	12.5	25	50
GRADES	N1	N2	N3	N4	N5	N6	N7	N8	N9	N10	N11	N12	
SYMBOLS	▽▽▽▽	▽▽▽	▽▽	▽	~								

TOLERANCE FREE DIMENSIONS TOLERANCE		MATERIALS: HDS		2023	NAME	DATE	2002275.2002
Dimns.	Dia	Length		DRAWN	BYK	14/09	
0.5 to 3	±0.05	±0.10		CHECKED	RVL	14/09	
3 to 6	±0.10	±0.15		APPROVED			
SCALE : NTS		QTY. :		PART NAME:		DRAWING No.	REV.
				HSKA63SFS20160WW		FWA063H-SFS20160	00

ITEM NO.	PART NUMBER	DESCRIPTION	QTY.
1	FWA063H-SFS20160	HSKA63SFS20160WW	1
2	SCWM16x1x20	STOPPER SCREW	1