

All Dimensions are in MM

Rev.No.	Ch.Let	Alterations	Date	Sign.	Appd.

For Customer Approval

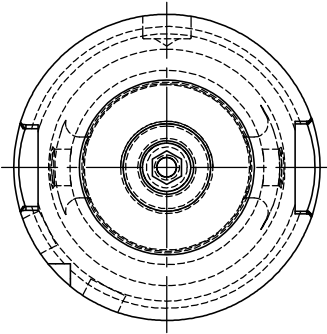
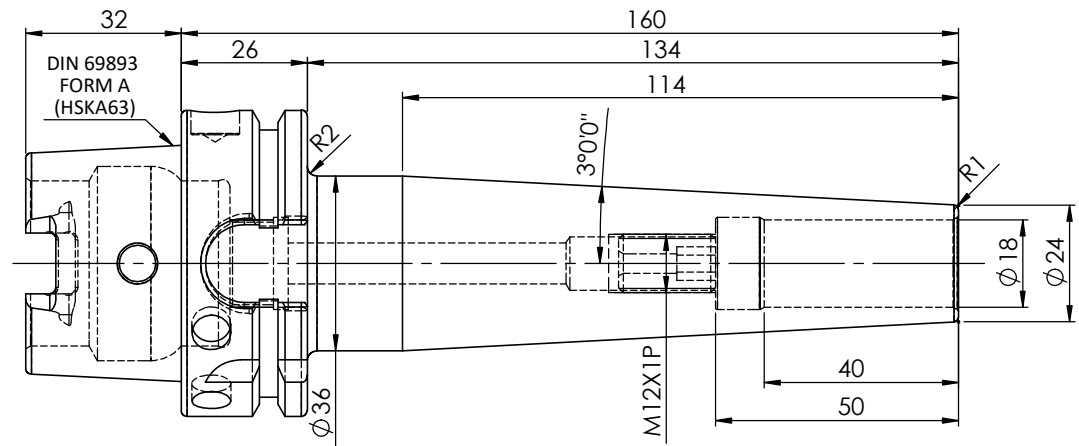
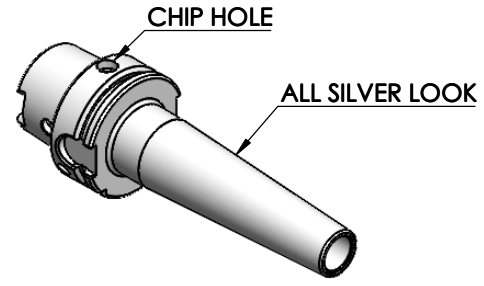

LABEL:

**2002275.1802
 SCHRUMPFUTTER SCHLANK 3°
 SHRINK FIT HOLDER SLIM 3°
 DIN 69893 HSK063A
 SRS 18mm X 160mm
 G2.5/25000 U/MIN**

**MARKING: DIN 69893 A HSK63A SFHS18 H160
 G2.5 25000 U/MIN**

Notes	
Balancing Value	G2.5 @25000 RPM
Approx Weight	1.30Kg

µ m	0.012	0.025	0.05	0.1	0.2	0.4	0.8	1.6	3.2	6.3	12.5	25	50
GRADES	N1	N2	N3	N4	N5	N6	N7	N8	N9	N10	N11	N12	
SYMBOLS	▽▽▽	▽▽	▽	▽	▽	▽	▽	▽	▽	▽	▽	▽	~

TOLERANCE	MATERIALS:	NAME	DATE
FREE DIMENSIONS	HDS	YK	03/09
TOLERANCE		RVL	03/09
Dimns.	Checked	APPROVED	
Dia	SCALE: NTS	QTY.:	
Length	PART NAME:		DRAWING No.
0.5 to 3	HSKA63SFS18160WW		2002275.1802
3 to 6			FWA063H-SFS18160
6 to 30			REV.
30 to 120			00
120 to 500			

ITEM NO.	PART NUMBER	DESCRIPTION	QTY.
2	SCWM12x1x20	STOPPER SCREW	1
1	FWA063H-SFS18160	HSKA63SFS18160WW	1

Grid lines labeled 1-8 horizontally and A-F vertically.