

All Dimensions are in MM

Rev.No.	Ch.Let	Alterations	Date	Sign.	Appd.

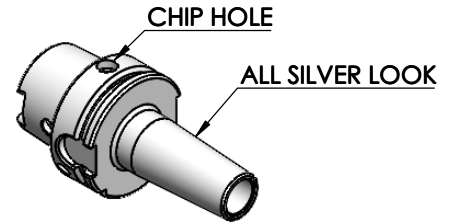

For Customer Approval

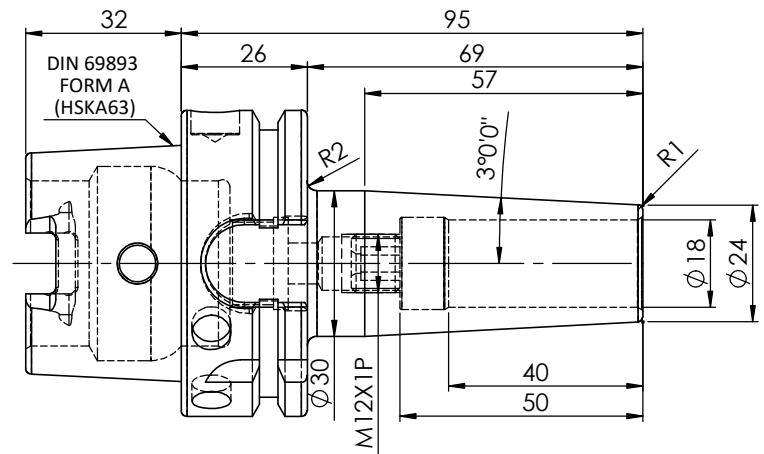
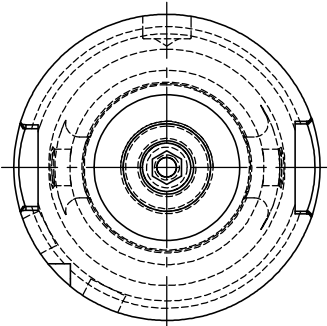

LABEL:

2002275.1800
SCHRUMPFUTTER SCHLANK 3°
SHRINK FIT HOLDER SLIM 3°
DIN 69893 HSK063A
SRS 18mm X 095mm
G2.5/25000 U/MIN

MARKING: DIN 69893 A HSK63A SFHS18 H095
G2.5 25000 U/MIN

Notes	
Balancing Value	G2.5 @25000 RPM
Approx Weight	0.90Kg

µ m	0.012	0.025	0.05	0.1	0.2	0.4	0.8	1.6	3.2	6.3	12.5	25	50	
GRADES	N1	N2	N3	N4	N5	N6	N7	N8	N9	N10	N11	N12		
SYMBOLS	▽▽▽	▽▽	▽	▽	▽	▽	▽	▽	▽	▽	▽	▽	~	
TOLERANCE FREE DIMENSIONS TOLERANCE	MATERIALS: HDS			NAME		DATE		2002275.1800						
Dimns.	Dia	Length	DRAWN		YK		03/09							
0.5 to 3	± 0.05	± 0.10	CHECKED		RVL		03/09							
3 to 6	± 0.10	± 0.15	APPROVED											
6 to 30	± 0.15	± 0.20	SCALE: NTS		QTY.:		PART NAME: HSKA63SFS18095WW							
30 to 120	± 0.20	± 0.25					DRAWING No. FWA063H-SFS18095							
120 to 500	± 0.30	± 0.50					REV. 00							

ITEM NO.	PART NUMBER	DESCRIPTION	QTY.
2	SCWM12X1-10	STOPPER SCREW	1
1	FWA063H-SFS18095	HSKA63SFS18095WW	1