

Rev.No.	Ch.Let	Alterations	Date	Sign.	Appd.

All Dimensions are in MM

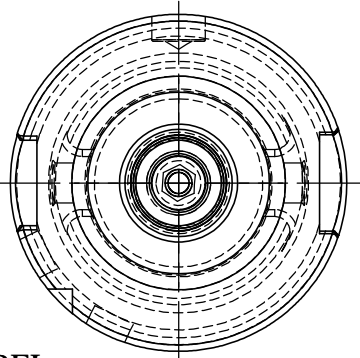
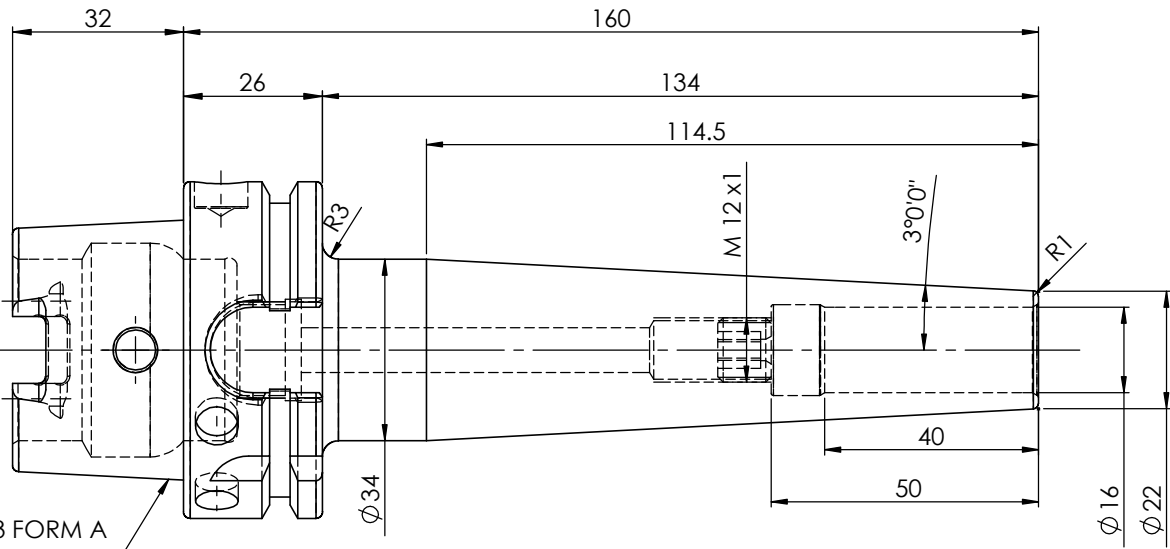
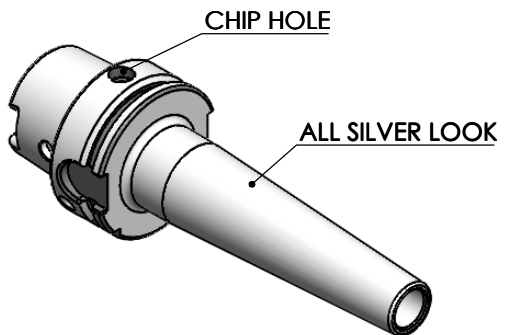

LABEL:

DIN 69893 FORM A
(HSKA63)

2002275.1602
SCHRUMPFUTTER SCHLANK 3°
SHRINK FIT HOLDER SLIM 3°
DIN 69893 HSK063A
SRS 16mm X 160mm
G2.5/25000 U/MIN

NOTE:

BALANCING : 2.5G @ 25000RPM

WEIGHT : 1.2 Kg

MARKING: DIN 69893 A HSK63A SFHS16 H160
G2.5 25000 U/MIN

µ m	0.012	0.025	0.05	0.1	0.2	0.4	0.8	1.6	3.2	6.3	12.5	25	50
GRADES	N1	N2	N3	N4	N5	N6	N7	N8	N9	N10	N11	N12	
SYMBOLS	▽▽▽	▽▽	▽	▽	▽	▽	▽	▽	▽	▽	▽	▽	~
TOLERANCE FREE DIMENSIONS TOLERANCE	MATERIALS: HDS		2021 NAME DATE		DRAWN SVR 08/09		CHECKED RVL 08/09		APPROVED		2002275.1602		
Dimns. Dia Length	PART NAME: HSKA63SFS16160WW		DRAWING No. FWA063H-SFS16160		SCALE: NTS QTY. :		REV. 00						
0.5 to 3 ± 0.05 ± 0.10													
3 to 6 ± 0.10 ± 0.15													
6 to 30 ± 0.15 ± 0.20													
30 to 120 ± 0.20 ± 0.25													
120 to 500 ± 0.30 ± 0.50													

ITEM NO.	PART NUMBER	DESCRIPTION	QTY.
1	FWA063H-SFS16160	HSKA63SFS16160WW	1
2	SCWM12X1-10	STOPPER SCREW-(B.O.)	1