

All Dimensions are in MM

Rev.No.	Ch.Let	Alterations	Date	Sign.	Appd.

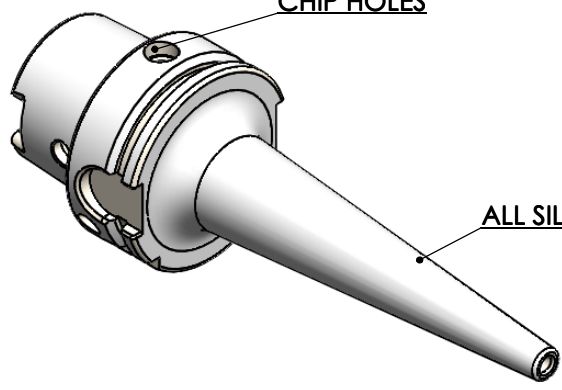

CHIP HOLES

ALL SILVER LOOK

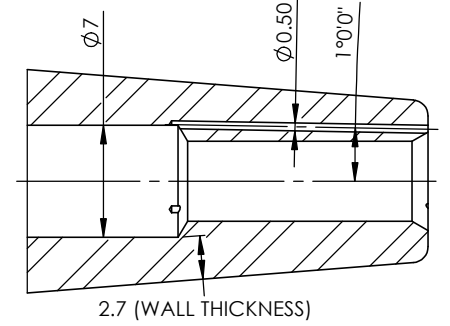
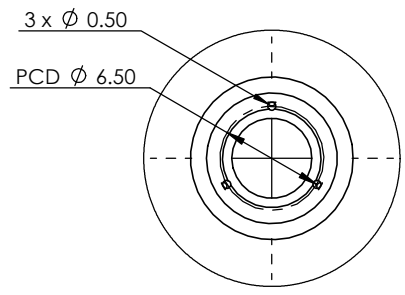

SECTION A-A
SCALE 3 : 1

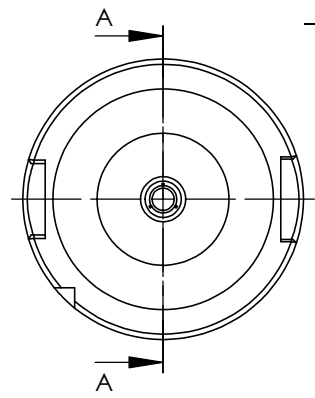

DIN69893 FORM A (HKA63)

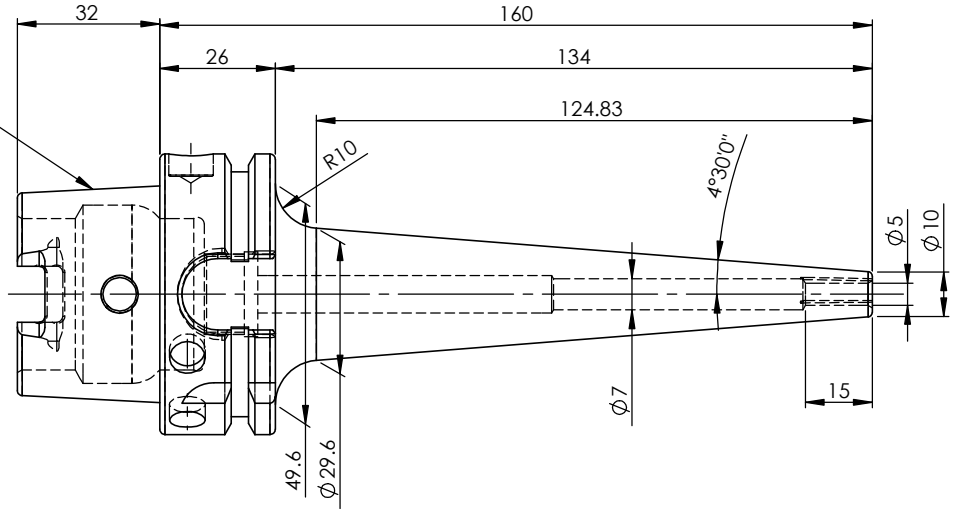

LABEL :

2002274.0502
SCHRUMPFUTTER MIT KK
SHRINK FIT HOLDER COOLANT CHANNEL
DIN69893 HSK63A
SR5 05mm X 160mm
G2,5/25000 U/MIN

MARKING : DIN69893 A HSK63A SFHC05H160
G2,5/25000 U/MIN

NOTE: WITHOUT BALANCING SCREW HOLES

NOTE :

BALANCING 2.5G@ 25000 RPM

Weight :1.0 Kg

	μ	m	0.012	0.025	0.05	0.1	0.2	0.4	0.8	1.6	3.2	6.3	12.5	25	50
GRADES			N1	N2	N3	N4	N5	N6	N7	N8	N9	N10	N11	N12	
SYMBOLS			▽▽▽	▽▽	▽	▽	▽	▽	▽	▽	▽	▽	▽	▽	~
TOLERANCE FREE DIMENSIONS	TOLERANCE		MATERIALS:		2022		NAME		DATE		2002274.0502				
Dimns.	Dia	Length	HDS		DRAWN		SVR		29/01						
0.5 to 3	± 0.05	± 0.10	CHECKED		RVL		29/01								
3 to 6	± 0.10	± 0.15	APPROVED												
6 to 30	± 0.15	± 0.20	SCALE : NTS		QTY. :										
30 to 120	± 0.20	± 0.25	PART NAME:					DRAWING No.					REV.		
120 to 500	± 0.30	± 0.50	HSKA63SFK05160WW					F1A063H-SFK05160					00		