

All Dimensions are in MM

Rev.No.	Ch.Let	Alterations	Date	Sign.	Appd.

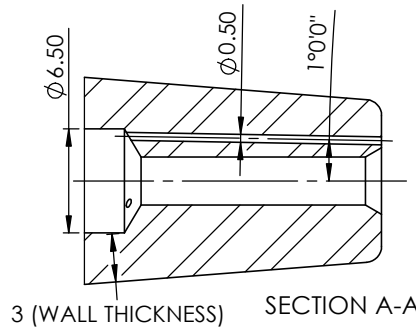

For Customer Approval

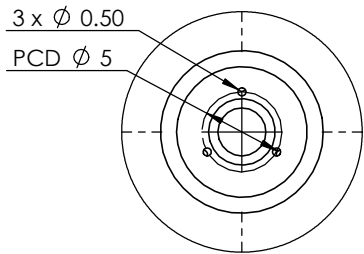
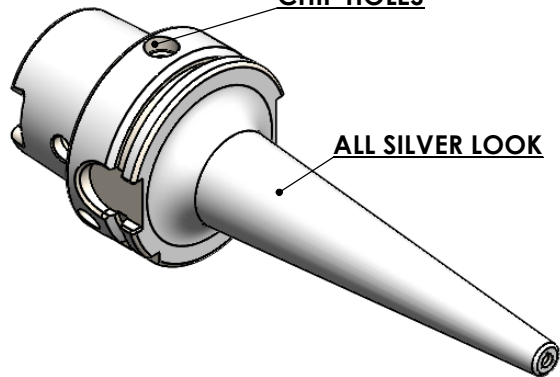
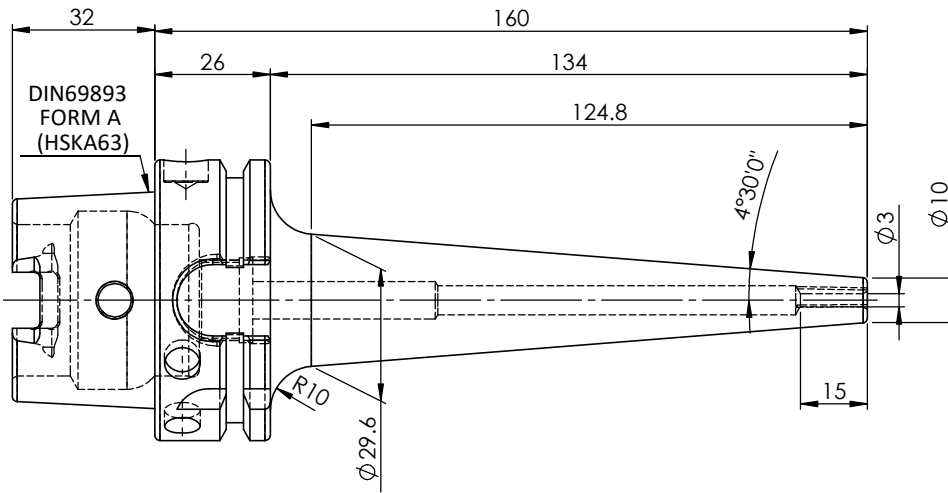
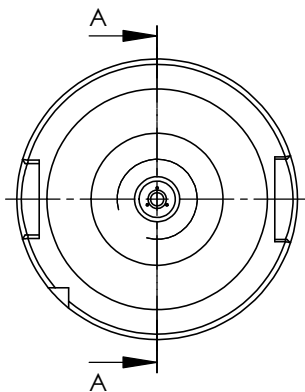

LABEL :

2002274.0302
SCHRUMPFUTTER MIT KK
SHRINK FIT HOLDER COOLANT CHANNEL
DIN69893 HSK63A
SR5 03mm X 160mm
G2,5/25000 U/MIN

MARKING : DIN69893 A HSK63A SFHC03 H160
G2,5/25000 U/MIN

NOTE: WITHOUT BALANCING SCREW HOLES

Notes	
Balancing Value	G2.5 @25000RPM
Approx Weight	1.0Kg

	μ	m	0.012	0.025	0.05	0.1	0.2	0.4	0.8	1.6	3.2	6.3	12.5	25	50
GRADES			N1	N2	N3	N4	N5	N6	N7	N8	N9	N10	N11	N12	
SYMBOLS			∇	∇	∇	∇	∇	∇	∇	∇	∇	∇	∇	∇	\sim
TOLERANCE FREE DIMENSIONS	MATERIALS:		2024		NAME		DATE		2002274.0302						
TOLERANCE	HDS		DRAWN		SVR		25/06								
Dimns.	Dia	Length	CHECKED		RVL		25/06								
			APPROVED												
			SCALE :		NTS		QTY. :		DRAWING No. F1A063H-SFK03160 REV. 00						
			PART NAME:												
			HSKA63SFK03160WW												