

All Dimensions are in MM

Rev.No.	Ch.Let	Alterations	Date	Sign.	Appd.

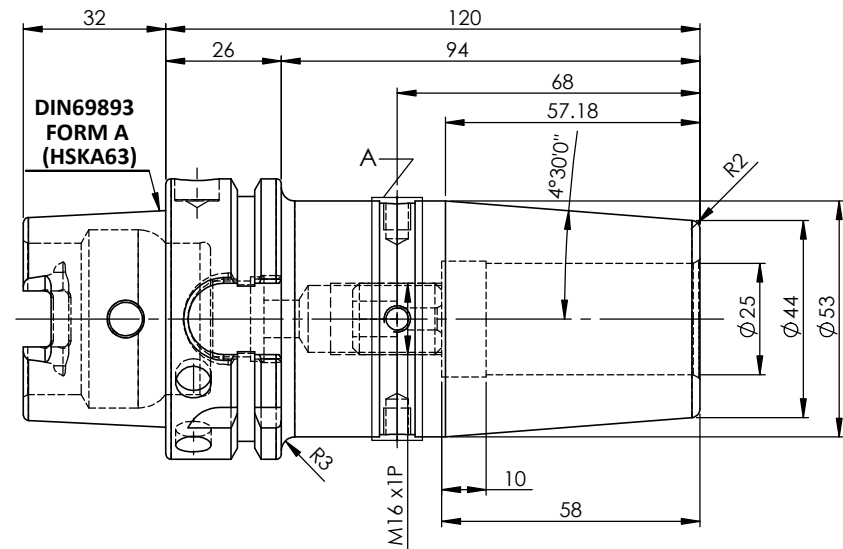
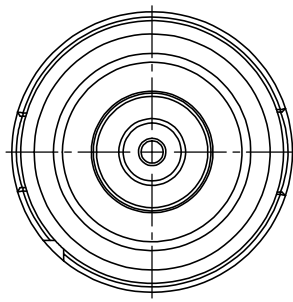
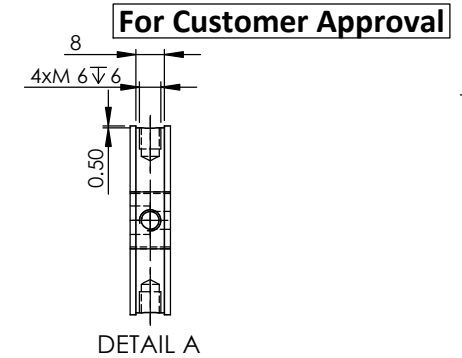

LABEL :

**2002273.2501
SCHRUMPFUTTER
SHRINK FIT HOLDER
DIN69893 HSK63A
SR 25mm X 120mm
G2,5/25000 U/MIN**

**MARKING : DIN69893 A HSK63A SR 25 H120
G2,5/25000 U/MIN**

Notes	
Balancing Value	G2.5 @25000 RPM
Approx Weight	1.80Kg

μ m	0.012	0.025	0.05	0.1	0.2	0.4	0.8	1.6	3.2	6.3	12.5	25	50
GRADES	N1	N2	N3	N4	N5	N6	N7	N8	N9	N10	N11	N12	
SYMBOLS	▽▽▽	▽▽	▽	▽	▽	▽	▽	▽	▽	▽	▽	▽	~

TOLERANCE	MATERIALS:	2024	NAME	DATE
FREE DIMENSIONS	HDS	DRAWN	YSK	06/09
TOLERANCE		CHECKED	RVL	06/09
Dimns.		APPROVED		
Dia		SCALE : NTS	QTY. :	
Length		PART NAME:		DRAWING No.
0.5 to 3	± 0.05	HSKA63SFC25120		F1A063H-SFC25120
3 to 6	± 0.10			REV.
6 to 30	± 0.15			00
30 to 120	± 0.20			
120 to 500	± 0.30			

2002273.2501

ITEM NO.	PART NUMBER	DESCRIPTION	QTY.
2	SCWM16x1x20	STOPPER SCREW	1
1	F1A063H-SFC25120	F1A063H-SFC25120	1