

All Dimensions are in MM

| Rev.No. | Ch.Lef | Alterations | Date | Sign. | Appd. |
|---------|--------|-------------|------|-------|-------|
| | | | | | |
| | | | | | |
| | | | | | |

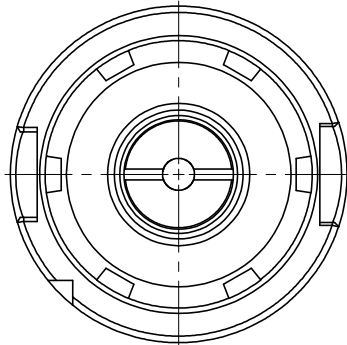

DIN 69893
FORM A
(HKA63)

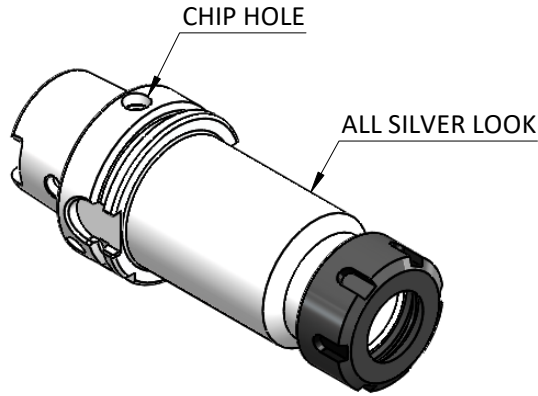
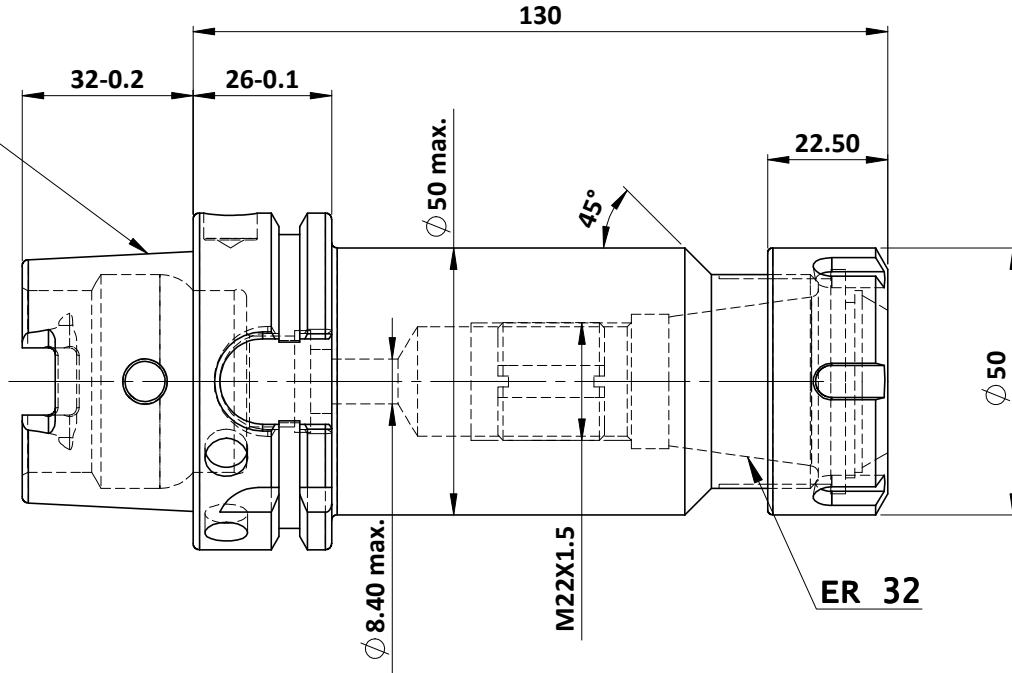

Label :

2002269.0605
SPANNZANGENAUFNAHME
ER COLLET CHUCK
DIN69893 HSK63A
ER 32 x 130mm
G2,5 / 25.000

WEIGHT : 1.75 kg

BALANCING 2.5G AT 25000 RPM

MARKING : DIN 69893 A HSK63A CCHER32 H130
G2.5 25000 U/MIN

| ITEM NO. | PART NUMBER | DESCRIPTION | QTY. |
|----------|------------------|---------------------|------|
| 1 | NUTER32 | COLLET NUT - ER32 | 1 |
| 2 | SCWM22X1.5 | STOPPER SCREW-(B.O) | 1 |
| 3 | FWA063H-ERS32130 | HSKA100CCHER32130WW | 1 |

| | μm | 0.012 | 0.025 | 0.05 | 0.1 | 0.2 | 0.4 | 0.8 | 1.6 | 3.2 | 6.3 | 12.5 | 25 | 50 |
|-----------------|------------|------------|----------------------------------|-------|---------------------------------|-----|------------|-----|-----|-----|-----|------|-----|----|
| GRADES | | N1 | N2 | N3 | N4 | N5 | N6 | N7 | N8 | N9 | N10 | N11 | N12 | |
| SYMBOLS | | ▽▽▽ | ▽▽ | ▽ | ▽ | ▽ | ▽ | ▽ | ▽ | ▽ | ▽ | ▽ | ▽ | ~ |
| TOLERANCE | MATERIALS: | 2017 | NAME | DATE | 2002269.0605 | | | | | | | | | |
| FREE DIMENSIONS | 16MnCr5 | DRAWN | SVK | 17/08 | | | | | | | | | | |
| TOLERANCE | | CHECKED | RVL | 17/08 | | | | | | | | | | |
| Dimns. | | APPROVED | | | | | | | | | | | | |
| | | SCALE: 2:1 | QTY.: | | | | | | | | | | | |
| 0.5 to 3 | ± 0.05 | ± 0.10 | PART NAME: HSKA63CCHER32130WW | | DRAWING No. FWA063H-ERS32130 | | REV. 00 | | | | | | | |
| 3 to 6 | ± 0.10 | ± 0.15 | | | | | | | | | | | | |
| 6 to 30 | ± 0.15 | ± 0.20 | | | | | | | | | | | | |
| 30 to 120 | ± 0.20 | ± 0.25 | | | | | | | | | | | | |
| 120 to 500 | ± 0.30 | ± 0.50 | | | | | | | | | | | | |